

HPF – Parker High Performance Flange System

Non-welding flange technology for highest performance



ENGINEERING YOUR SUCCESS.

Note! The customer should provide the requisite certifications, classifications and test and inspection data whenever a quotation or order is placed.

For your safety!

Under certain circumstances, tube fittings can be subjected to extreme loadings such as vibrations and uncontrolled pressure peaks.

The reliability and safety of the products and their conformity to the applicable standards can only be assured by using genuine Parker components and following Parker assembly instructions.

Failure to follow this rule can adversely affect the functional safety and reliability of products, cause personal injury, property damage, and result in loss of your guarantee rights.



Subject to alteration

© Copyright 2021, Parker Hannifin Corporation. All Rights Reserved.

Content

Introduction..... page 4

HPF System description..... 5

Complete Piping Solutions (CPS) 8

Technical Data 11

Installation 21

Machines and tooling..... 29

Ordering information/Nomenclature 33

HPF – SAE 3000/ISO 6162-1 35

HPF – SAE 6000/ISO 6162-2 45

HPF – Flange ISO 6164 55

High Pressure Connectors Europe

The market leader's expertise

Outstanding performance

Since 1929 the Parker Hannifin Corporation is a reliable partner in the sector of fluid power technology. Today Parker offers a variety of more than 100,000 quality products for many different industries and applications, making the company the manufacturer with the broadest experience and product range in the field of hydraulic and pneumatic components. Most of its expertise is based on the production of precision-made tube fittings, one of the first product groups of the corporation. A proof of Parker's excellent performance.

Many years of experience in product design, engineering as well as application and production technology make the High Pressure Connectors Europe to a leading manufacturer - a position which is even more strengthened by sharing knowledge and technology within the huge family of the Parker Corporation.

Grand experience

On the basis of multiple experience and knowledge gained about important industrial, mobile, offshore and further applications, Parker creates the broadest and best performing range of tube connection systems in the world.

Why is Parker a distinguished manufacturer of fittings?

There are many reasons but the most important ones are the core competences in design and production which distinguish every Parker product.

Global standardisation

The Parker Fluid Connectors Group supports national and international standardisation activities. In cooperation with the products' users, experienced Parker engineers make their contribution to the work of organisations such as SAE International, BSI and DIN. The resulting ISO standards for fluid connectors are of essential importance for all globally operating companies in the hydraulic and pneumatic industries.

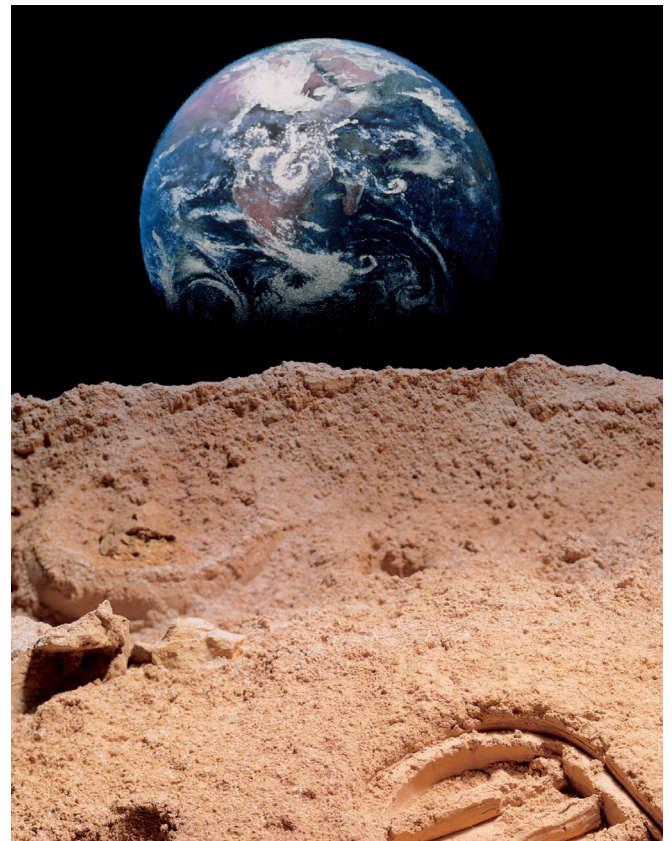

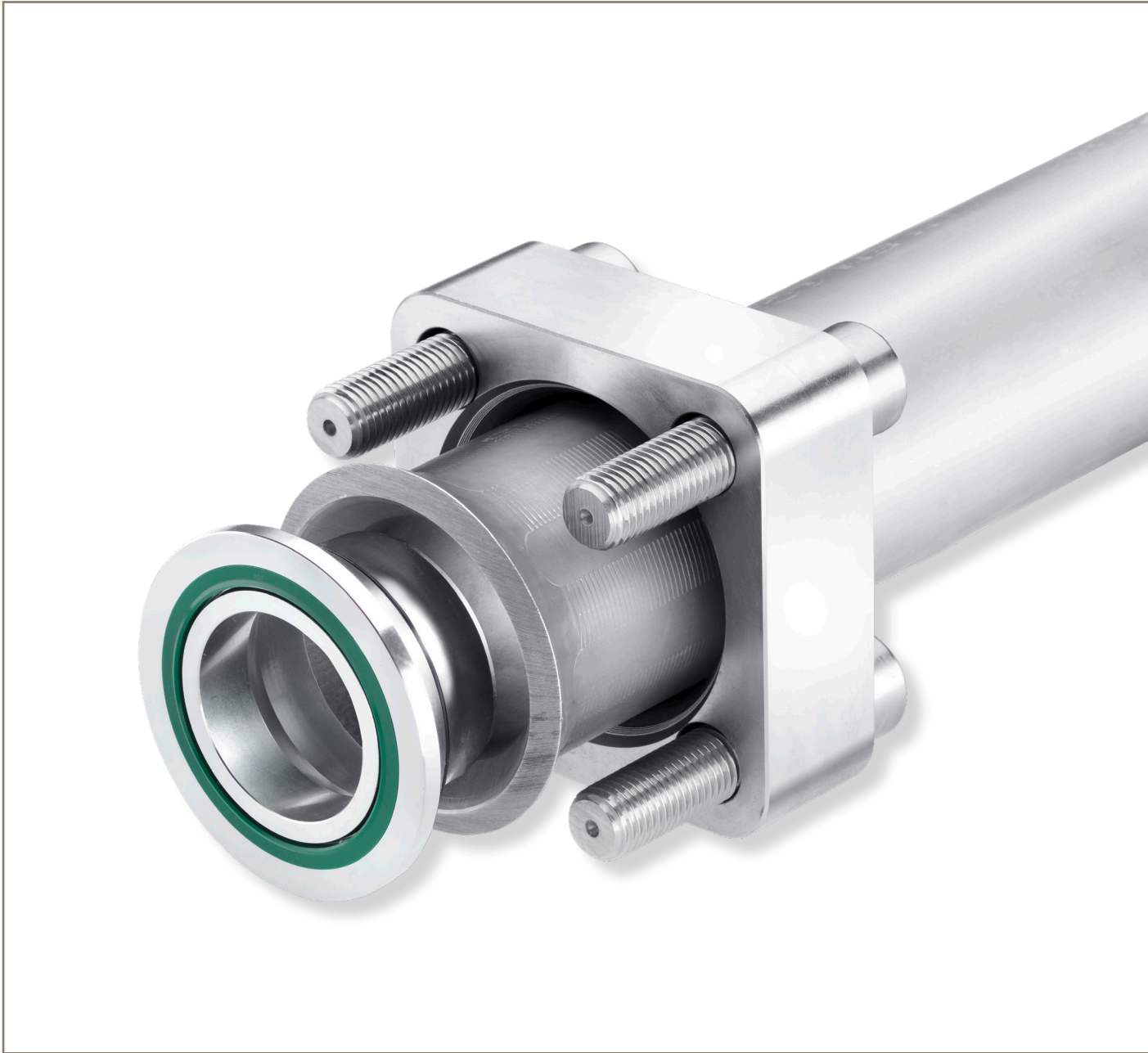

HPF System description

ENGINEERING YOUR SUCCESS.

HPF System description

HPF – The technology

Parker's mechanical flange system for the toughest requirements

Parker's HPF System has been specially designed and developed to meet today's and future requirements of marine, mobile hydraulic and industrial equipment: high performance and high pressure.

The system

HPF is generally applicable for working pressures up to 420 bar. But the design opens the door to go even beyond this pressure rating: by choosing a suitable combination of flange, insert and tube the pressure rating can be increased to 500 bar.

The System is adjusted to standard tube dimensions with diameters from 25 to 150 mm and wall thickness up to 20 mm. It is designed for flange patterns according to ISO 6162-1 (SAE J518, code 61), ISO 6162-2 (SAE J518, code 62) and ISO 6164.

Learning from nature

The best solutions for complex design problems can often be found in nature. The flaring of a tube is similar to the shape of a branch where it joins the trunk of a tree: The tube is flared by hydraulic axial pressure giving it a parabolic shaping, increasing from 10° up to 37°. The initial gentle incline of the shaping guarantees additional safety against strong system vibrations. The DGVV confirmed the capability of this unique, patented system especially for the use in hydraulic and mechanical presses as well as in hydraulic power systems for injection moulding machines. Beside that, the system is an ideal solution for marine and offshore applications. It is type approved by various classification societies like DNV/GL, LR and others.



The HPF Connector - Strong teamwork for the toughest demands

HPF flanges are equipped with a specially designed and hardened inner grip contour, providing excellent additional tear-off safety for the connection. Optionally some sizes are equipped with special lockrings. A soft sealed, shaped insert is placed into the flared end of the tube. The tube side of the insert is equipped with an O-Ring. On the port side the sealing is guaranteed by an O-Ring or by the special profile F37 Seal.

The F37 Seal was developed especially for the use with SAE flanges. These special seals guarantee a high form stability. Compared to standard O-Rings, their mechanical properties prevent gap extrusion, even when the flanges "breathe" under pressure. The special profile of the F37 Seal is ideally adapted to higher pressures or unsuitable surface finish of the flanges. The application of these soft-sealing elements both on the port side and tube side guarantees the gas leak tightness of the HPF connector. As the insert does not have a toothed profile, it can be easily assembled repeatedly.

Tube forming

The tube forming is performed by the Parflange® HPF machines; they can either be purchased or rented for a certain period

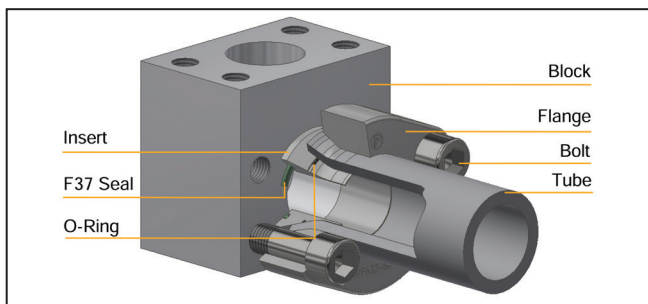

of time. If required, assembly of ready-to-install straight or manipulated HPF tube lines can be carried out by a Parker CPS Piping Center.

Flanging instead of welding: Error-free and riskless assembly

Nowadays many tube connections are welded. However, as even the best welding operator may make a mistake, each welding seam has to be tested, leading to an enormous loss of time and a significant increase of costs. Even finding trained staffed may be critical. Apart from enormous time savings for the joint preparation itself, HPF offers various advantages compared to the welding solution:

- Welding galvanic zinc-plated tubes is always critical. With HPF zinc-plated tubes can be used, there is no further painting necessary.
- Welding seams must be descaled and often be stained. Dealing with this process and substances is an environmental risk.
- Welded tubes need to be intensively cleaned inside. HPF tube assemblies do not require any special cleaning, reducing flushing time and costs during initial system startup.
- The flanging process does not cause noxious gases, thus eliminating explosion risks and fire hazards.
- The HPF tube forming is a machined cold forming process. Therefore there is no need for X-raying the connection.



HPF – The technology

Conventionally welding connection

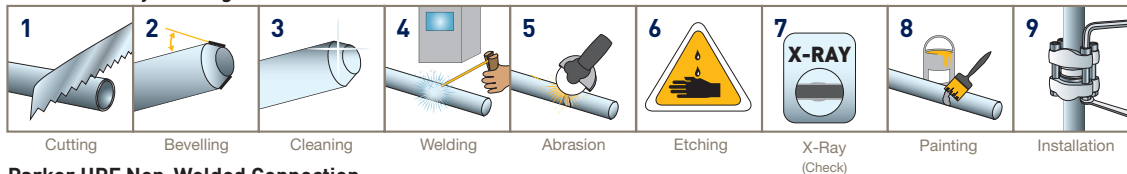

Parker HPF Non-Welded Connection

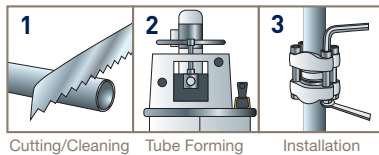

Feature	Customer Value
No welding	- Reduced preparation time per joint - No costly inspection of welds (X-ray)
No post-weld cleaning	- No acid cleaning costs - No waste cleaning costs - No safety risk - Environmentally friendly
No welding stress corrosion possible	- Maximum piping lifetime - Reduced maintenance costs
No „hot work“ permit required	- Operation can take place in areas with fire risk without interruption of production - Reduced downtime costs - Higher level of safety
Work shop prefabrication	- High quality joints with better accuracy due to workshop conditions - Minimized need for on-site work - Shorter installation time - Shorter maintenance/downtime - Shorter total project time
Cleanliness	- Minimized need for repair and replacement of hydraulic system components such as pumps, cylinders, ... - Reduced overall flushing time and costs
Easy dismantling and reassembling	- Quicker, easier and more flexible installation - Reduced downtime costs for maintenance and repair

Cr(VI)-free corrosion protection

All components do of course have surfaces which are free of Cr(VI) platings. Parker is highly aware of its responsibility for the environment and human health. Therefore Parker has completely renounced the use of Cr(VI) containing surfaces.

Personnel and environment-friendly

By comparing the individual operations for a welded line with Parker flanges connected lines, significant cost savings opportunities become immediately obvious. No vapours putting health at risk are released, in contrast to conventional welding processes. Consequently, usage is possible in locations with high requirements such as, for example, offshore oil platforms. In addition to this flaring machine design errors in the preparation of flanges are virtually unknown. Stress corrosion cracking generated during welding operations is history and the life of the finished tubing system is increased. Cold formed Parflange® technologies save power and energy compared to welding and require neither degreasers nor anti-corrosion agents. When galvanized tubes are used, post-galvanization can be omitted because the zinc-coating is not impaired by flaring. Parker flange connector components are delivered in state of the art Cr(VI)-free surfaces.

We deliver all the component parts securely packed to the required location. Reliable delivery on the date advised. And then we come to professional assembly – our specialists will willingly take it on for you. After testing and a trial run, you can press the start button to make your production a success.

Principles account for success

The concept of this system is the customer interaction with advice, design, preassembly (with fittings, flanges and machined tubes), delivery and installation as a complete package cannot be beaten. Supportive planning, high-quality products and safe working processes offer the ultimate synergy in time and cost saving. And of course, individual Piping Solutions principles are also available to you.

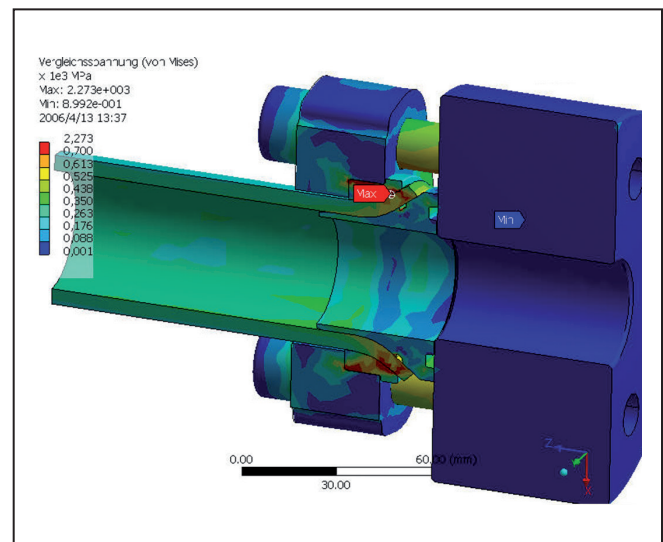

Complete Piping Solutions (CPS)

Homogeneous solutions offer efficiency

From Components to full service.

Parker offers you the competent complete solution for hydraulic systems. From advice via design and pre-configuring to delivery and installation - everything with the best quality and reliability. You only have one contact. You take the pressure off your own team, release capacity and overall save a lot of time. You achieve new efficiency.

Excellent complete solution.

Complete Piping Solutions from Parker are always to the customer's advantage. Equally high quality in all areas and available around the world.

The complete solution from a single source frees up customer capacity and lowers the need for customers to provide coordination effort. As a supplier of piping system solutions we offer our customers significant added value.

Advantages that pay off.

- High-quality system technology
- Saves time
- Saves money
- Customised user solutions
- Environmentally friendly
- Global supply
- Integration into existing systems

Advice	Briefing/design meeting
Design	Pipe layout Pipe dimensioning Drawings Documentation
Prefabrication	Pipe bending Pipe end processing Pipe cleaning
Delivery	Assembly/ Dispatch Documentation
Assembly	On-site advice On-site assembly Testing and flushing Documentation



Pipe bending



The requirements increase

So does our performance

In order to comply with the market and customer requirements in this segment we have aligned our performance to this. The following overview aims to emphasise the range of services offered by CPS Germany.

Development and design:

- Modern CAD systems can process all common 3D and 2D data formats and simulate installation situations
- The projects are produced as required by or in cooperation with the customer. These may be new systems or upgrades
- It may require taking pipe measurements on-site using a modern measurement system. These data can be transferred to the CAD system
- Data from the measurement system are used later for quality control in order to ensure an ideal and secure

production process

Cold bending:

- After creating the data required for production it is transferred to the machines. The available bending machines process tubes and pipes with diameters from 6 x 1 mm to 190 x 20 mm (thin-walled \varnothing 220 x 6 mm)

Tube end processing:

- Modern CNC controlled machines are available for processing pipe ends. Tube end processing is carried out based on internal standards

Tube cleaning:

- Tube cleaning using the ISO 4406 / NAS 1638 standard
- Permanent control of the pollution and cleanliness level with modern measuring devices

Pressure test:

- Pressure test to customer specifications possible



- Documentation at the customer's request

Installation / support:

- Delivery of pre-configured tube systems to the customer's desired address
- Installation of tube systems whilst taking into account the parameters and work steps set in the installation manual
- Installation by end customer training conducted by Parker



Video



ENGINEERING YOUR SUCCESS.

Parker Onsite Service Containers

High-quality piping systems at a single-source

The Parker Onsite Service Containers include all assembly machines, that are needed to prepare the assembly of tubes from 6 mm to 60 mm. Even larger pipes up to 10"/273 mm outer diameter can be prepared on request.

The range of high-quality machines covers all fitting and connections available in Parker, like EO-2, F37, HPF etc. All machines fulfill highest requirements concerning quality of production and continuous assembly results. In addition to that the Onsite Service Containers contain all necessary equipment for piping installation like bending, cutting, cleaning machines and can be shipped worldwide.

By using the Parker Onsite Service Container concept, customers enlarge their flexibility and can decide, whether to buy or to rent the containers.

Key features

- High precision assembly machines for pipes from 6 mm up to 10"/273 mm
- Continuous assembly results
- Worldwide available
- Customized concepts on request



Flushing Unit

For top-quality end products

Parker flushing units are an additional service to clean the piping systems before it will be connected with main users. The safety of the whole systems will be increased and maintenance cost decreased.

Flushing units from Parker are capable to flush pipes up to 10" (273 mm). The flushing capacity is about 3000 l/min but can be enlarged by using additional units.

Technical Specifications

- 20Ft DNV 2.7-1 CSC Lloyds Offshore certified container
- Flushing medium mineral hydraulic oil
- Flow (flushing) 3000 l/min. 75 bar adjustable
- Pressure testing 630 bar
- 6 Electric motors 400 V 50Hz / 480 V 60Hz
- Particle counter
- Pressure Filters 2 - 10 micron
- Return Filters 2 - 20 micron
- Tank capacity 6000 l

Key features

- Increased safety
- Less maintenance costs
- Cleanliness Documentation
- On-site service engineer



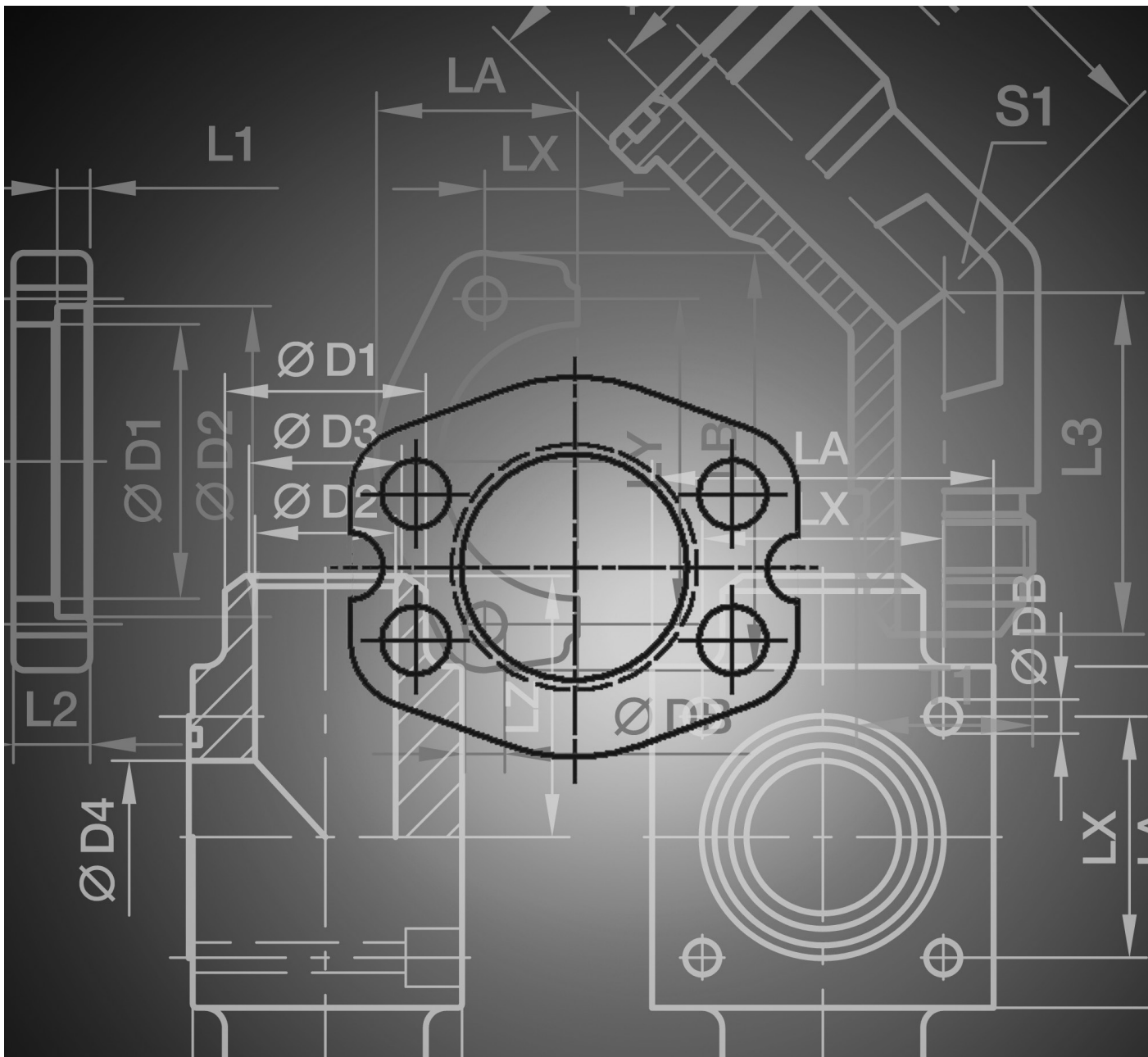

Technical Data

ENGINEERING YOUR SUCCESS.

Tube and pipe specification

Recommended carbon steel tubes and pipes

Parker recommends the use of cold drawn seamless and regular annealed (abbreviation +N) hydraulic tubes and pipes acc. to DIN-EN 10305 (old DIN 2391).

For the assembly of steel flanges, steel tubes made of material E355 (ST52.4 +N) are recommended.

- + precision dimension/shape
- + high pressure capability
- + clean inside (no scale)
- + excellent scaling surface after flaring

Welded tubes and pipes

Tubes and pipes acc. to below specification but welded and cold redrawn instead of seamless drawn are usually suitable. Pressure capability might be reduced due to the welding seam zone.

Welding seam quality might affect flaring surface results.

Hot rolled pipes

Hot rolled pipes are not recommended for the following reasons:

Hot rolled pipes do not have precision dimensions and may slip in machine dies. They have scales inside and outside. The inside scales affect the cleanliness level of the fluid and reduces fatigue levels. Used in flaring process the scales will contaminate the flaring tools (high cleaning effort) and cause poor flare surface quality.

The required maximum working pressure is calculated either acc. to DIN or DNV.

Material specifications & values for DIN-calculation

E355+N / St.52.4 (1.0580) acc. to DIN EN 10305-4

Tensile strength	min. 490 N/mm ²
Yield strength	min. 355 N/mm ²
Fatigue strength	265 N/mm ² ¹⁾
Elongation at break	min. 22 %

¹⁾ No standard value, Experience value

Material specifications & values for DNV-calculation

Due to Parker's high quality standards, the DNV-calculation assumes higher values for tensile strength and yield strength. These values are experience values. Nominal pressure calculation based on these mechanical properties requires a certification in accordance with 3.1 - EN 10204, which confirms the mechanical properties.

E355+N / St.52.4 (1.0580) acc. to DIN EN 10305-4

Tensile strength	533 N/mm ²
Yield strength	min. 355 N/mm ²
Proof stress (Yield strength / 1.8)	197 N/mm ²

Tube calculation for industrial and mobile applications acc. to DIN rules

DIN 2413 I, only for static load

Calculation of working pressure of steel tubes for static stress up to 120°C. Corrosion - additional allowances are not considered for the calculation of pressures. Tubes with a diameter of OD/ID > 2 are calculated for static stress in accordance with DIN 2413 III, but with K = yield strength.

$$P = \frac{20 * K * s * c}{S * D}$$

- P = permissible working pressure [bar]
- K = yield strength [N/mm²]
- s = tube wall thickness [mm]
- c = factor for wall thickness allowance
 - = 0.8 for Tube-OD 4-5
 - = 0.85 for Tube-OD 6-8
 - = 0.9 from Tube-OD 10
 - = 0.9 for all stainless steel tubes
- S = Safety factor = 1.5
- D = tube outside diameter [mm]

DIN 2413 III, for dynamic load

Calculation of working pressure of steel tubes for dynamic stress up to 120°C. Corrosion - additional allowances are not considered for the calculation of pressures.

$$P = \frac{20 * K * s * c}{S * (D + s * c)}$$

- P = permissible working pressure [bar]
- K = fatigue strength [N/mm²]
- s = tube wall thickness [mm]
- c = factor for wall thickness allowance
 - = 0.8 for Tube-OD 4-5
 - = 0.85 for Tube-OD 6-8
 - = 0.9 for Tube-OD 10-80
 - = 0.9 for all stainless steel tubes
- S = safety factor = 1.5
- D = tube outside diameter [mm]

Burst pressure calculation

Calculation of static burst pressure for seamless tubes acc. to Faupel-von-Mises.

$$BP = R_{p0.2} * 10^{\frac{2}{\sqrt{3}}} \ln \frac{D}{d} * (2 - \frac{R_{p0.2}}{R_m})$$

- BP = Min. static burst pressure [bar]
- R = tensile strength [N/mm²]
- R_{p0.2} = 0.2% proof stress, yield strength [N/mm²]
- D = Tube outside diameter [mm]
- d = Tube inside diameter [mm]

Tube calculation for marine and offshore acc. to DNV rules

Calculation of working pressure of steel and stainless steel tubes for ship building acc. to DNV Part 4, Chapter 6, Section 6.

$$P = \frac{20 * \sigma_t * e * t_0}{D - t_0}$$

- P = permissible working pressure [bar]
- BP = approximate burst pressure [bar]
- σ_t = permissible stress [N/mm²]
calculated from the lower value off:

t₀ = tube wall thickness without allowances [mm]

- t_n = tube wall thickness nominal [mm]
- a = factor for wall thickness allowance
 - = 0.8 for Tube-OD 4-5, 0.85 for Tube-OD 6-8, 0.9 for Tube-OD >=10
 - = 0.875 for Schedule Pipes
 - = 0.9 for all stainless steel tubes
- b = bending allowance

- c = corrosion tolerance, c = 0.3 mm for hydraulic steel tube, c = 0 mm for SS tubes
- e = strength ratio: for seamless tubes e = 1
- D = tube outside diameter [mm]
- R_m = min. tensile strength [N/mm²]
- K = min. yield strength or min 0.2% proof stress [N/mm²]

Calculation of burst pressure:

$$BP = \frac{20 * R_m * t_n * a}{D - t_n * a}$$

- | | |
|---|---|
| stainless steel: | carbon steel: |
| σ _t = $\frac{R_m}{2.7}$ or $\frac{K}{1.6}$ | σ _t = $\frac{R_m}{2.7}$ or $\frac{K}{1.8}$ |

$$t_0 = t_n * a - c - b$$

$$b = \frac{1}{2.5} * \frac{D}{R} * t_0$$

$$b = 0.1333 * t_0 \text{ (at } R/D=3) \rightarrow t_0 = \frac{t_n * a - c}{1.1333}$$

Technical Data

Seamless E0 steel tubes | Material E355+N / St.52.4 (1.0580)

Pressures acc. DIN rules (landbased and industrial applications); Tubes supplied acc. DIN EN 10305-1

1. DIN 2413 I static pressure (W.P.) capability for straight pipe including manufacturing tolerance.
2. DIN 2413 III dynamic pressure (W.P.) capability for straight pipe including manufacturing tolerance.
3. Burst pressure (B.P.) calculation acc. to Faupel-von-Mises

Material E355+N / St. 52.4 (1.0580)		d _a Outer-Ø (mm)	OuterØ Tolerance (mm)	s Wal- thickness (mm)	d _i Inner-Ø (mm)	Design pressure		3 Burst pressure bar	Weight kg/m
Surface Phosphated and oiled	Cr(VI)-free					1 DIN 2413 I static PN bar	2 DIN 2413 III dynamic PN bar		
Order code									
	R25X3ST52CF	25.0	±0.08	3.0	19.0	511	344	1435	1.628
	R25X4ST52CF	25.0		4.0	17.0	682	445	2016	2.072
	R30X4ST52CF	30.0	±0.08	4.0	22.0	568	379	1622	2.565
	R30X5ST52CF	30.0		5.0	20.0	710	461	2120	3.083
	R38X4ST52CF	38.0	±0.15	4.0	30.0	448	306	1236	3.354
	R38X5ST52CF	38.0		5.0	28.0	561	374	1597	4.069
	R38X6ST52CF	38.0		6.0	26.0	673	440	1984	4.735
	R42X4ST52CF	42.0		±0.20	4.0	34.0	406	279	1105
	R42X5ST52CF	42.0	5.0		32.0	507	342	1422	4.562
R50X5ST52	R50X3ST52CF	50.0	±0.20	3.0	44.0	256	181	668	3.477
	R50X5ST52CF	50.0		5.0	40.0	426	292	1167	5.549
	R50X6ST52CF	50.0		6.0	38.0	511	344	1435	6.511
	R50X8ST52CF	50.0		8.0	34.0	682	445	2016	8.286
R60X6ST52	R60X5ST52CF	60.0	±0.25	5.0	50.0	355	247	953	6.782
	R60X6ST52CF	60.0		6.0	48.0	426	292	1167	7.990
	R60X8ST52CF	60.0		8.0	44.0	568	379	1622	10.259
	R65X8ST52CF	65.0		±0.30	8.0	49.0	524	352	1477
R66X8.5ST52	R66X8.5ST52CF	66.0	±0.30	8.5	49.0	549	367	1557	12.053
R73X7ST52	R73X7ST52CF	73.0	±0.35	7.0	59.0	408	281	1113	11.393
R75X12.5ST52		75.0	±0.35	12.5	50.0	710	461	2120	19.266
R80X8ST52		80.0	±0.35	8.0	64.0	426	292	1167	14.205
R80X10ST52		80.0		10.0	60.0	533	357	1504	17.263
R88X14ST52		88.0	±0.40	14.0	60.0	678	443	2002	25.549
R90X5ST52		90.0	±0.40	5.0	80.0	237	168	616	10.481
R90X9ST52		90.0		9.0	72.0	426	292	1167	17.978
R97X12ST52		97.0	±0.45	12.0	73.0	527	354	1486	25.154
R101.6X16ST52		101.6	±0.50	16.0	69.6	671	439	1978	33.776
R115X15ST52		115.0	±0.50	15.0	85.0	556	371	1580	36.992
R130X15ST52		130.0	±0.70	15.0	100.0	492	332	1372	42.540
R150X15ST52		150.0	±0.80	15.0	120.0	426	292	1167	49.939

Other sizes on request!



Seamless E0 steel tubes | Material E355+N / St.52.4 (1.0580)

Pressures acc. DNV rules (marine and offshore applications); Tubes supplied acc. DIN EN 10305-1

1. DNV Bended pipe including manufacturing and corrosion tolerances.
2. DNV Straight pipe including manufacturing and corrosion tolerances.
3. Burst pressure (B.P.) calculation = Based on Tensile value, wall thickness tolerance not included.

Material E355+N / St. 52.4 (1.0580)		d _a Outer-Ø (mm)	Outer-Ø Tolerance (mm)	s Wall- thickness (mm)	d _i Inner-Ø (mm)	Design pressure		3 Burst pressure bar	Weight kg/m
Surface Phosphated and oiled	Cr(VI)-free					1 DNV PN bar	2 DNV PN bar		
Order code									
	R25X3ST52CF	25.0	±0.08	3.0	19.0	365	418	1454	1.628
	R25X4ST52CF	25.0		4.0	17.0	519	599	2030	2.072
	R30X4ST52CF	30.0	±0.08	4.0	22.0	424	487	1640	2.565
	R30X5ST52CF	30.0		5.0	20.0	555	641	2132	3.083
	R38X4ST52CF	38.0		4.0	30.0	327	375	1254	3.354
	R38X5ST52CF	38.0	±0.15	5.0	28.0	426	490	1615	4.069
	R38X6ST52CF	38.0		6.0	26.0	529	611	1999	4.735
	R42X4ST52CF	42.0		4.0	34.0	294	336	1122	3.748
	R42X5ST52CF	42.0	±0.20	5.0	32.0	381	438	1441	4.562
R50X5ST52	R50X3ST52CF	50.0		3.0	44.0	174	199	680	3.477
	R50X5ST52CF	50.0	±0.20	5.0	40.0	315	361	1184	5.549
	R50X6ST52CF	50.0		6.0	38.0	390	448	1454	6.511
	R50X8ST52CF	50.0		8.0	34.0	546	631	2030	8.286
R60X6ST52	R60X5ST52CF	60.0		5.0	50.0	259	297	969	6.782
	R60X6ST52CF	60.0	±0.25	6.0	48.0	319	366	1184	7.990
	R60X8ST52CF	60.0		8.0	44.0	445	512	1640	10.259
	R65X8ST52CF	65.0	±0.30	8.0	49.0	407	468	1496	11.245
R66X8.5ST52	R66X8.5ST52CF	66.0	±0.30	8.5	49.0	429	494	1576	12.053
R73X7ST52	R73X7ST52CF	73.0	±0.35	7.0	59.0	308	353	1131	11.393
R75X12.5ST52		75.0	±0.35	12.5	50.0	583	674	2132	19.266
R80X8ST52		80.0	±0.35	8.0	64.0	325	372	1184	14.205
R80X10ST52		80.0		10.0	60.0	418	481	1523	17.263
R88X14ST52		88.0	±0.40	14.0	60.0	554	640	2017	25.549
R90X5ST52		90.0		5.0	80.0	169	193	627	10.481
R90X9ST52		90.0	±0.40	9.0	72.0	326	374	1184	17.978
R97X12ST52		97.0	±0.45	12.0	73.0	416	478	1505	25.154
R101.6X16ST52		101.6	±0.50	16.0	69.6	550	635	1993	33.776
R115X15ST52		115.0	±0.50	15.0	85.0	444	511	1599	36.992
R130X15ST52		130.0	±0.70	15.0	100.0	388	445	1390	42.540
R150X15ST52		150.0	±0.80	15.0	120.0	332	380	1184	49.939

Other sizes on request!

Technical Data

Pressure reductions and temperatures

Required pressure reductions (dependent on the material) with reference to the catalogue pressures for higher temperatures. Both metal flange component material and elastomeric sealing compound have to be selected according to the temperature requirements of the system.

Material	Pressure reduction of permissible operating temperature in °C														
	-60	-54	-40	-35	-25	+20	+50	+100	+120	+150	+175	+200	+250	+300	+400
Steel, flange components			-10 %*)			0 %				-11 %	-19 %				
Steel, tubes			-10%			0 %				-19 %		-27 %			
Sealing material NBR (e.g. Perbunan)															
Sealing material FKM															
Sealing material Polyurethane (P5008)															

*) Parker should be informed about low temperature applications (<-20°C) or requirements acc. DIN EN 148-1 ("Charpy-V")

	Permissible operating temperature
	Ambient temperature of hydraulic and pneumatic applications
	Temperature not permissible

Perbunan = registered trademark of Bayer

Calculation example:

Temperature = 200 °C

Material = Steel

Pressure reduction = 19 %

Pressure reduction tubes = 19 %

PN tube 30x4.0 (St.52.4), DIN 2413 III = 379 bar

Formula:

$$PN_{\text{Connection } 200^\circ\text{C}} = \frac{420 \text{ bar}}{100\%} \times (100\% - 19\%) = 340 \text{ bar}$$

$$PN_{\text{tube } 200^\circ\text{C}} = \frac{379 \text{ bar}}{100\%} \times (100\% - 19\%) = 307 \text{ bar}$$

F37 seal

The F37 seal was developed especially for use with flanges. Compared to a standard O-ring the special profile of the F37 seal is ideally adapted to higher pressures or unsuitable surface finish of the flanges.

The particularly low compression set of the polyurethane compound ensures dimensional stability of the seal over a large temperature range. Its high extrusion resistance prevents gap extrusion even if the flanges "breathe" under pressure. Due to

good abrasion resistance, less preparation is necessary on the surface finish of the sealing area of the flange. The frequently occurring "pumping" phenomenon of O-rings is prevented by the shape of the F37 seal.

Application area

Static sealing for Flanges

Working pressure: ≤ 600 bar

Working temperature: see table above

Materials

The F37 seal is made of a polyurethane based Parker compound with a hardness of approx. 93 Shore A. In comparison with other polyurethane materials currently available on the market, it excels because of its increased heat resistance, improved performance against hydrolysis and low compression values.

For special requirements (pressure, temperature, speed, application in water, HFA-, HFB-fluids etc.), please contact our Consultancy Service, so that suitable materials and/or designs can be recommended.

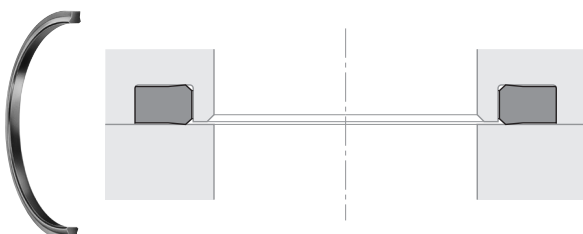



Pressure reductions and temperatures for ball valves

Body, adapters, stem and ball materials	Pressure reduction of permissible operating temperatures TB in °C													
	-60	-50	-40	-30	-20	-10	0	+20	+80	+100	+120	+130	+150	+200
Free-Cutting steel, not suitable for gas applications!	0%													
Low-Alloy Steel	-25%					0%								
Stainless steel	0%										-11%			
Duplex Steel	0%										-20%			

Ball seat material	Pressure reduction of permissible operating temperatures TB in °C													
	-60	-50	-40	-30	-20	-10	0	+20	+80	+100	+120	+130	+150	+200
POM	0%													
Cast Iron GG25	0%													

Stem and adapter sealing materials	Pressure reduction of permissible operating temperatures TB in °C													
	-60	-50	-40	-30	-20	-10	0	+20	+80	+100	+120	+130	+150	+200
Acrylonitrile-butadienerubber (NBR, Buna N)	0%													
Low-temp NBR Compound	0%													
FKM						0%								
Low-temp FKM Compound	0%													
EPDM	0%													

 Permitted operating temperature
 Temperature not permitted

A test pressure of 1.5 x PN applies to all ball valves in accordance with DIN 3230 T5 and ISO 5108 for body.

1.1 x PN applies to ball seats.

The nominal pressure specifies the admissible working pressure at 20°C. Please consider the pressure reduction at higher temperature.

The safety factor for burst pressure tests is a minimum of 2.4 times the nominal pressure.

$P_{Burst} = 2.4 \times PN$

Leakage tests are done acc. DIN EN 12266 leakage rate A (No visually noticeable leakage during the duration of the test with fluid or air).

For other materials than listed, please contact Parker HPCE.

Application testing and verification is customer responsibility.

Flow characteristics

Hydraulic systems are in most cases only rated with a flow velocity defined on the basis of experience. The pressure losses in lines are not taken into account, or measured later on when testing the system. As the pressure losses increase proportionally greater than the flow resistance, it is important to achieve the best rating of the system, so that they are already taken into account when planning the tube connections. Calculation is not as difficult as it is often thought, and this chapter is intended to provide a guideline. Besides, it provides information on how excessive pressure losses can be avoided, because pressure losses result in losses in performance and excessive heat. Noise occurs and possibly cavitation in suction lines.

Medium

All indications given to flow restrictions and to flow properties refer exclusively to liquids. For gaseous media, the variable density of the gas must additionally be taken into account.

Units

c = Flow velocity [m/s]

d = Pipe inside diameter [m]

L = Pipe length [m]

ρ = Pressure [Pa], 1 bar = 100000 Pa

V = Flow rate [m³/s], 1 m³/s = 60000 l/min

λ = Pipe friction factor

$\nu(T)$ = Kinematic viscosity of the medium depending on temperature

$\rho(T)$ = Density of the medium depending on temperature $\left[\frac{\text{m}^2}{\text{s}} \right]$

ζ = Individual pressure loss coefficient $\left[\frac{\text{kg}}{\text{m}^3} \right]$

Only base units have been used. This has the advantage that the formula do not contain correction factors and there is no danger of confusion, e.g. that values are used with the wrong unit. In case values are given in other units - the flow rate is e.g. often given in l/min - it is advisable to convert them into the base units before starting calculation.

Pressure losses in pipe lines

To calculate pressure losses in pipe lines, it must first be determined whether there is a laminar or a turbulent flow. Laminar flow is homogenous and without turbulence. In case of turbulent flow, the losses increase much more quickly.

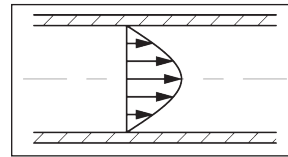

Flow profile with laminar flow

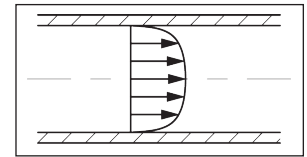

Flow profile with turbulent flow

The kind of flow is defined by the Reynolds' number. With a Reynolds' number of more than 2320, the flow changes to turbulent. The Reynolds' number is calculated according to the formula:

$$Re = \frac{c \cdot d}{\nu(T)}$$

The Reynolds' number is a non-dimensional number. The critical fluid velocity at which the flow regime can change, is thus calculated from:

$$c_{cr} = 2320 \cdot \frac{\nu(T)}{d} \left[\frac{\text{m}}{\text{s}} \right]$$

With a given flow rate, the fluid velocity can be calculated according to the formula:

$$c = \frac{\dot{V} \cdot 4}{d^2 \cdot \pi} \left[\frac{\text{m}}{\text{s}} \right]$$

Subsequently, the pipe friction factor λ is a function of the Reynolds' number and also depends on the roughness of the pipe. As hydraulically smooth pipes can generally be assumed in hydraulic applications, the pipe friction factor λ is calculated according to the following formula:

$$\text{laminar flow, (Re < 2320): } \lambda = \frac{64}{Re}$$

$$\text{turbulent flow, (Re > 2320): } \lambda = \frac{0,3164}{\sqrt[4]{Re}}$$

Finally, if all factors are known, the pressure loss in certain pipe lines can be calculated according to the formula:

$$\Delta p = \lambda \cdot \frac{L}{d} \cdot \frac{\rho(T) \cdot c^2}{2} \text{ [Pa]}$$

Calculation of individual losses

A hydraulic system does not only incorporate pipes, but also valves, fittings, pipe bends etc. that cause flow losses. These individual losses are often much higher than the pipe losses and are calculated according to the following formula:

$$\Delta p = \zeta \cdot \rho(T) \cdot \frac{c^2}{2} \text{ [Pa]}$$

Tube bends

With pipe bends, the pressure loss coefficient results from the ratio of bend to inside diameter (R/d).

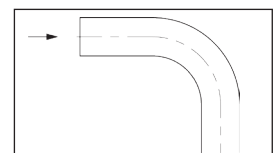

Bend radius/Inside diameter	Pressure loss coefficient ζ
2	0.21
4	0.14
6 and more	0.11

Flow diameter and wall thickness

Determining tube sizes for hydraulic systems

Proper tube material, type and size for a given application and type of fitting are critical for efficient and trouble-free operation of the fluid system. Selection of proper tubing involves choosing the right tube material, and determining the optimum tube size (O.D. and wall thickness).

Proper sizing of the tube for various parts of a hydraulic system results in an optimum combination of efficient and cost effective performance.

A tube that is too small causes high fluid velocity, which has many detrimental effects. In pressure lines, it causes high friction losses and turbulence, both resulting in high pressure drops and heat generation. High heat accelerates wear in moving parts and rapid aging of seals and hoses, all resulting in reduced component life. High heat generation also means wasted energy, and hence, low efficiency.

Too large tubes increase system cost. Thus, optimum tube sizing is very critical. The following is a simple procedure for sizing tubes.

Determine required flow diameter

Use table to determine recommended flow diameter for the required flow rate and type of line.

The table is based on the following recommended flow velocities:

Avoid flow rates > 8m/s!

The resulting forces are high and can destroy the tube lines.

$$\text{Pressure lines} - 3 \rightarrow 5 \left[\frac{\text{m}}{\text{s}} \right]$$

$$\text{Return lines} - 2 \rightarrow 4 \left[\frac{\text{m}}{\text{s}} \right]$$

$$\text{Suction lines} - 1 \left[\frac{\text{m}}{\text{s}} \right]$$

If you wish to use different velocities than the above, use one of the following formulae to determine the required flow diameter.

$$\text{Tube - I.D. [mm]} = 4.61 \cdot \sqrt{\frac{\text{Flow} \left[\frac{\text{ltr.}}{\text{min}} \right]}{\text{Velocity} \left[\frac{\text{m}}{\text{s}} \right]}}$$

Maximum flow [l/min]	Flow diameter in millimeters		
	5 m/s Pressure lines	3 m/s Return lines	1 m/s suction lines
10	6.5	8.4	14.6
15	8.0	10.3	17.9
20	9.2	11.9	20.6
25	10.3	13.3	23.1
30	11.3	14.6	25.3
35	12.2	15.7	27.3
40	13.0	16.8	29.2
45	13.8	17.9	30.9
50	14.6	18.8	32.6
55	15.3	19.7	34.2
60	16.0	20.6	35.7
65	16.6	21.5	37.2
70	17.2	22.3	38.6
75	17.9	23.1	39.9
80	18.4	23.8	41.2
85	19.0	24.5	42.5
90	19.6	25.3	43.7
95	20.1	25.9	44.9
100	20.6	26.6	46.1
110	21.6	27.9	48.4
120	22.6	29.2	50.5
130	23.5	30.3	52.6
140	24.4	31.5	54.5
150	25.3	32.6	56.5
160	26.1	33.7	58.3
170	26.9	34.7	60.1
180	27.7	35.7	61.8
190	28.4	36.7	63.5
200	29.2	37.6	65.2
220	30.6	39.5	68.4
240	31.9	41.2	71.4
260	33.2	42.9	74.3
280	34.5	44.5	77.1
300	35.7	46.1	79.8
320	36.9	47.6	82.5
340	38.0	49.1	85.0
360	39.1	50.5	87.5
380	40.2	51.9	89.9
400	41.2	53.2	92.2
450	43.7	56.5	97.8
500	46.1	59.5	103.1
550	48.4	62.4	108.1
600	50.5	65.2	112.9
650	52.6	67.9	117.5
700	54.5	70.4	122.0
750	56.5	72.9	126.3
800	58.3	75.3	130.4
850	60.1	77.6	134.4
900	61.8	79.8	138.3
950	63.5	82.0	142.1
1000	65.2	84.2	145.8
1050	66.8	86.2	149.4
1100	68.4	88.3	152.9
1150	69.9	90.3	156.3
1200	71.4	92.2	159.7
1250	72.9	94.1	163.0
1300	74.3	96.0	166.2
1350	75.8	97.8	169.4
1400	77.1	99.6	172.5
1450	78.5	101.4	175.5
1500	79.8	103.1	178.5



Installation

ENGINEERING YOUR SUCCESS.

Tube selection

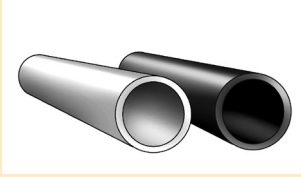

- Choose components acc. to the relevant catalogue table

Selection of flange components

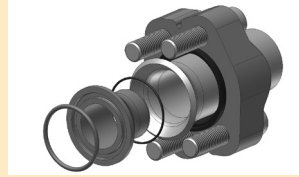

- Select suitable tube acc. to catalogue specification
- △ Components of other producers are strictly not permitted!

Tube preparation

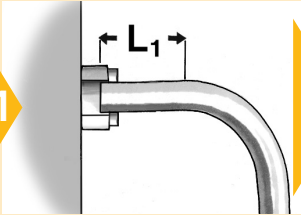

- Minimum straight length **L1** before bend

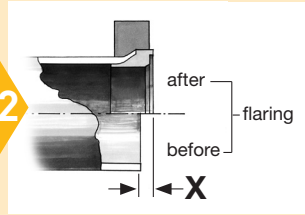

- Tube length before flaring determined by distance **X**

Size ISO 6162-1 3000psi Inch	Tube O.D. x W.T. mm	Tube length determination X in mm	Recommen- ded minimum distance L1 mm
1 1/4	42x4.0	4.0	125
1 1/2	50x5.0	5.0	130
1 1/2	50x6.0	3.5	
2	50x5.0	12.0	125
2	60x5.0	6.5	
2	60x6.0	6.0	
2 1/2	60x6.0	7.5	
2 1/2	73x7.0	9.0	170
3	90x5.0	5.0	
3	90x9.0	11.0	

Size ISO 6162-2 6000psi Inch	Tube O.D. x W.T. mm	Tube length determination X in mm	Recommen- ded minimum distance L1 mm	
3/4	25x3.0	8.0	130	
3/4	25x4.0	8.5		
1	30x4.0	8.0		
1	30x5.0	8.0		
1	38x4.0	5.0	125	
1	38x6.0	7.0		
1 1/4	38x4.0	9.5		
1 1/4	38x5.0	10.0		
1 1/4	38x6.0	12.0	130	
1 1/4	42x5.0	6.5		
1 1/2	38x5.0	16.5		
1 1/2	50x3.0	3.5		
1 1/2	50x5.0	6.5	170	
1 1/2	50x6.0	5.5		
1 1/2	50x8.0	8.0		
2	50x5.0	16.0		
2	50x6.0	16.0	160	
2	50x8.0	18.0		
2	60x6.0	12.0	165	
2	60x8.0	10.0		
2	60x10.0	12.5		
2	65x8.0	8.0		
2	66x8.5	7.0		
2 1/2	75x12.5	25.5		180
2 1/2	80x10.0	21.5		
3	97x12.0	on request		on request

Size ISO 6164 420 bar Inch	Tube O.D. x W.T. mm	Tube length determination X in mm	Recommen- ded minimum distance L1 mm
2	50x8.0	18.0	130
2	60x8.0	11.0	
2	60x10.0	12.5	
2 1/2	60x8.0	20.5	180
2 1/2	75x12.5	16.5	185
2 1/2	80x10.0	12.5	180
3	80x8.0	16.0	185
3	80x10.0	16.0	
3	88x14.0	16.0	
3	90x9.0	11.0	
3	97x12.0	4.0	215*
3	101.6x16.0	11.5	
3 1/2	101.6x16.0	14.0	275*
4	115x15.0	5.0	285*
4 1/2	130x15.0	11.5	275*
5	150x15.0	13.0	290*

*Parameter for Parflare HPF170

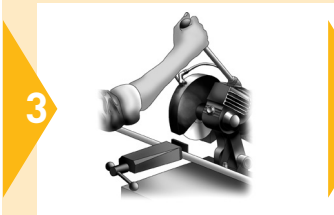

- Cut tube squarely
- max. $\pm 1^\circ$ deviation
- △ Burrs can result in sealing problems or tool wear

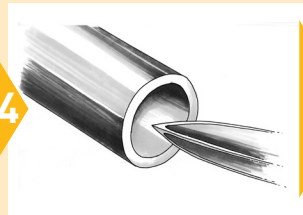

- Proper deburring and cleaning of inner and outer diameter
- Chamfer 1 mm x 45° max
- △ Burrs can result in sealing problems or tool wear

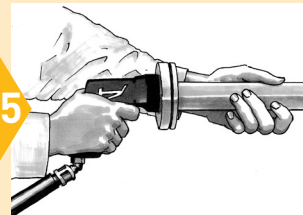

- Clean tube before flaring
- Adhere to project specification
- △ Dirt can result in sealing problems or tool wear

Tube forming with Parflare HPF 120

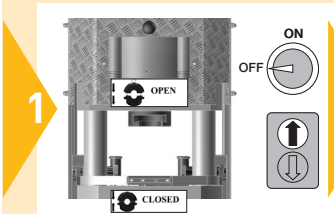

- Open safety cover
- Latch in „OPEN“ position
- Cylinder in „BACK“ position
- △ Main switch „OFF“ during setting



- Select suitable tools according to chart
- Check flaring pin for dirt, wear and damage
- Check flaring dies for dirt, wear and damage
- See also page 28

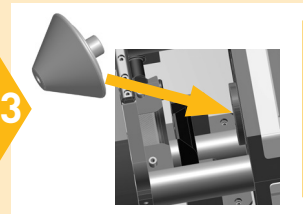

- Insert flaring pin
- Fix with bolt

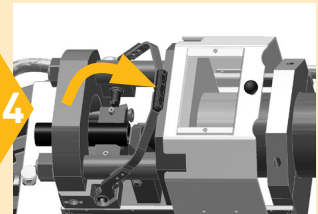

- For inserting clamping jaws in „OPEN“ position
- Then insert lower clamping jaw
- Tip lower clamping jaw to make things easier
- Push clamping jaw on guide bolt to stop



- Adjust tube stop wheel according to chart
- Tighten locking screw for tube stop adjustment

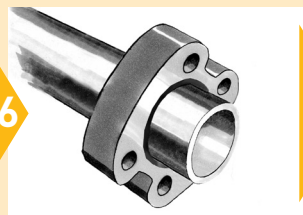

- △ Two-part flange connectors with separate locking ring must not be assembled without a locking ring
- Place flange components on tube before flaring
- Note correct flange direction
- Then locking in correct direction

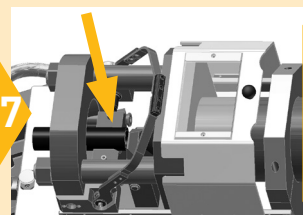

- Insert tube so that it lies against the stop
- Place upper jaw half
- △ Support and secure long and heavy tubes horizontally

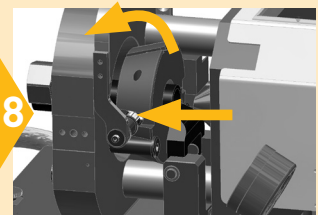

- Swing latch in position „CLOSED“
- Pull clamping jaws with tube into front plate

Installation

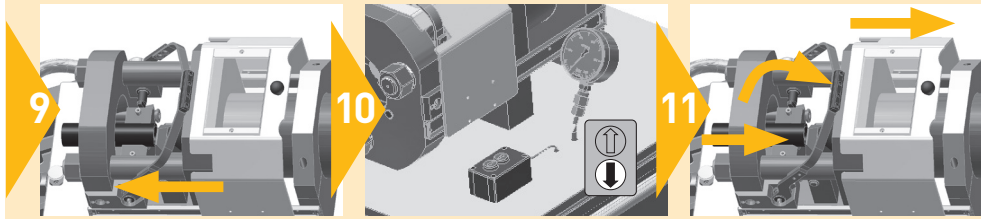



⚠ Lubricate flaring pin and pipe inside surface with high pressure grease

- Close protective hood
- Switch on main switch
- Machine is ready for flaring operation

- Start flaring operation by actuating button
- Observe pressure on manometer
- On reaching chart value, end flaring operation
- Run flaring pin to start position

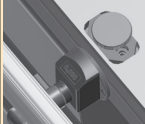
- Open protective hood
- Push tube with clamping jaw completely out of the front plate up to the stop of both guide bolts
- Clamp in „OPEN“ position
- Lift upper jaw and remove tube

 Tube O.D. x W.T. mm	 Tube stop mm	 Pressure Assembly bar
25x3.0	5.5	100
25x4.0	5.5	150
30x4.0	6.0	200
30x5.0	7.0	200
38x4.0	3.5	200
38x5.0	3.5	200
38x6.0	3.5	300
42x4.0	4.0	250
42x5.0	5.0	400
50x3.0	6.0	150
50x5.0	6.5	250
50x6.0	8.5	300
50x8.0	9.0	600
60x5.0	1.0	250
60x6.0	1.0	300
60x8.0	6.0	500
60x10.0	7.0	700
65x8.0	5.0	300
66x8.5	6.0	500
73x7.0	4.0	400
75x12.5	10.0	700
80x8.0	8.0	600
80x10.0	9.0	700
88x14.0	10.0	700
90x5.0	6.0	300
90x9.0	8.0	600
97x12.0	8.0**	670**
101.6x16.0	8.0**	670**
115x15.0	9.0**	670**
130x15.0	9.0**	670**
150x15.0	13.5**	670**

- Setting values are recommendations only
- Adjust setting to specific tube quality and tolerance
- **Parameter for Parflare HPF170

The operation of the Parflare HPF 170 machine is slightly different, please read the machine manual before use.



Checking the flare



- Clean flare for inspection
- Visual check: Check sealing surface for cracks, burrs, scratches and pitting
- ⚠ Do not use any tubing with faulty sealing faces (risk of leakage)

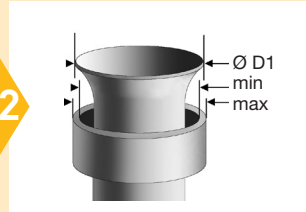

- Dimensional check of the flare according to chart
- ⚠ Do not use any tubing with incorrectly dimensioned flaring diameters

Tube O.D. x W.T. mm	Flare Ø D1 ± 1mm	Tube O.D. x W.T. mm	Flare Ø D1 ± 1mm
25x3.0	36.0	60x5.0	74.0
25x4.0	36.0	60x6.0	74.0
30x4.0	42.0	60x8.0	78.0
30x5.0	43.0	60x10.0	78.0
38x4.0	49.0	65x8.0	82.0
38x5.0	49.0	66x8.5	84.0
38x6.0	49.0	73x7.0	86.0
42x4.0	54.0	75x12.5	92.0
42x5.0	54.5	80x8.0	95.0
50x3.0	64.0	80x10.0	95.0
50x5.0	64.0	88x14.0	104.0
50x6.0	65.0	90x5.0	105.0
50x8.0	65.0	90x9.0	105.5
		97x12.0	119.0
		101.6x16.0	118.0
		115x15.0	143.0
		130x15.0	154.0
		150x15.0	178.0

Installation HPF Flange connection

For sea water environment applications additional protection against corrosion is recommended.



- Tube end must be clean
- Fix insert
- If necessary, use plastic hammer
- ⚠ Avoid damage to sealing surfaces

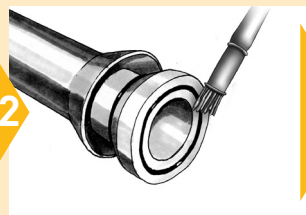

- Insert sealing ring
- To protect the sealing ring from damage during repeat assembling, it can also be lubricated if necessary.
- The use of Parker O-Lube or Super-O-Lube is recommended (please pay attention to the material-, media- and temperature resistance).

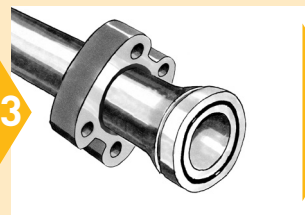



- Check correct sealing of sealing rings
- Sealing face must not be dirty or damaged

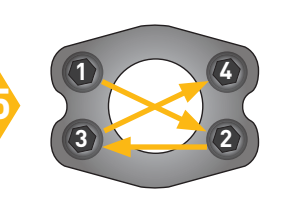

- Position flange and place bolts
- ⚠ Tube assembly must be stress-free at both ends
- ⚠ Bolts must move freely
- ⚠ Do not use shorter bolts indicated in the catalogue!
- Parker recommends to lubricate the bolts (recommended lubricant: MOLYKOTE® G-RAPID PLUS)

Installation







- It is recommended to tighten this flange types with minimum two tools.

- Tighten the bolts diagonally in small steps until the appropriate torque is reached (page 27).
 - 1: Tighten the bolts lightly by hand with the Allen key.
 - 2: Apply 30% of the specified torque in accordance with the picture above.
 - 3: Apply 60% of the specified torque in accordance with the picture above.
 - 4: Apply 100% of the specified torque in accordance with the picture above.
 - 5: Repeat step 4.
 - 6: Apply 100% of the specified torque in a circular direction (clockwise).

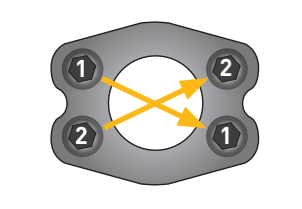
Using two tools





- Tighten the bolts diagonally in small steps until the appropriate torque is reached (page 27).
 - 1: Tighten the bolts lightly by hand with the Allen key.
 - 2: Apply 30% of the specified torque in accordance with the picture above.
 - 3: Apply 60% of the specified torque in accordance with the picture above.
 - 4: Apply 100% of the specified torque in accordance with the picture above.
 - 5: Repeat step 4.
 - 6: Apply 100% of the specified torque in a circular direction (clockwise).

Using four tools





- Tighten the bolts diagonally in small steps until the appropriate torque is reached (page 27).
 - 1: Tighten the bolts lightly by hand with the Allen key.
 - 2: Apply 100% of the specified torque in accordance with the picture above.
 - 3: Apply 100% of the specified torque in a circular direction (clockwise).



The following applies whatever the number of tools:

- In cases where the tube lines must undergo pressure testing, and where the proof pressure exceeds the flange working pressure (e.g. PN x 1.5 proof pressure), a repeat of step 3 is required after pressure testing.
- Further tightening can be required after a week of operation, depending on the dynamics of the system. We recommend checking at least 10% of the connectors in accordance with the following procedure:
 - Apply 70% of the specified torque.
 - If the bolts do not move, the pre-tensioning is in order and no further tightening is required.
 - If the bolts can be turned, all the connectors must be retightened with 90% of the specified torque (only once).

Recommended torques:

Size ISO 6162-1 3000 psi Inch	Tube O.D. x W.T. mm	Bolts mm	Torque 10.9 Nm*
1 1/4	42x4.0	M10	50
1 1/2	50x5.0	M12	75
1 1/2	50x6.0	M12	75
2	50x5.0	M12	80
2	60x5.0	M12	80
2	60x6.0	M12	80
2 1/2	60x6.0	M12	90
2 1/2	73x7.0	M12	90
3	90x5.0	M16	210
3	90x9.0	M16	210

Size ISO 6164 420 bar Inch	Tube O.D. x W.T. mm	Bolts mm	Torque 10.9 Nm*
2	50x8.0	M16	210
2	60x8.0	M16	
2	60x10.0	M16	
2 1/2	60x8.0	M20	400
2 1/2	75x12.5	M20	
2 1/2	80x10.0	M20	
3	80x8.0	M24	600
3	80x10.0	M24	
3	88x14.0	M24	750
3	90x9.0	M24	
3	97x12.0	M24	
3	101.6x16.0	M24	
3 1/2	101.6x16.0	M24	
4	115x15.0	M30	
4 1/2**	130x15.0	M20	400
5**	150x15.0	M24	750

Size ISO 6162-2 6000 psi Inch	Tube O.D. x W.T. mm	Bolts mm	Torque 10.9 Nm*
3/4	25x3.0	M10	45
3/4	25x4.0	M10	
1	30x4.0	M12	
1	30x5.0	M12	
1	38x4.0	M12	80
1	38x6.0	M12	
1	38x6.0	M12	
1	38x6.0	M12	
1 1/4	38x4.0	M14 / (M12)	120 / (80)
1 1/4	38x5.0	M14 / (M12)	
1 1/4	38x6.0	M14 / (M12)	
1 1/4	42x5.0	M14 / (M12)	
1 1/2	38x5.0	M16	210
1 1/2	50x3.0	M16	
1 1/2	50x5.0	M16	
1 1/2	50x6.0	M16	
1 1/2	50x6.0	M16	
1 1/2	50x8.0	M16	
2	50x5.0	M20	400
2	50x6.0	M20	
2	50x8.0	M20	
2	60x6.0	M20	
2	60x8.0	M20	
2	60x10.0	M20	
2	65x8.0	M20	
2	66x8.5	M20	
2 1/2	75x12.5	M24	550
2 1/2	80x10.0	M24	
3	97x12.0	M30	

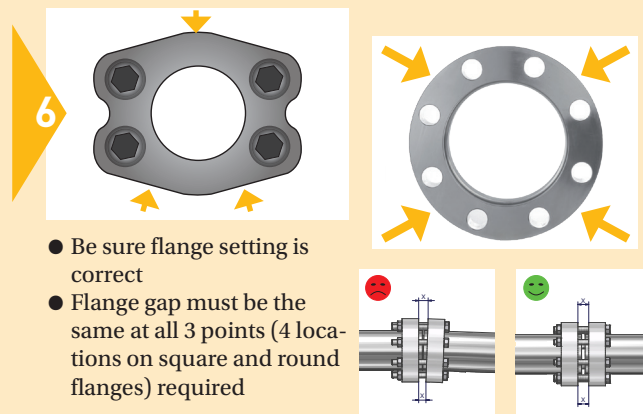

* Lubricate head seating and threads on bolts with (MOLYKOTE G-RAPID PLUS)
 ** Round flange design
 Torques for 8.8-bolts (ISO6162-1) respectively 8.8- and 12.9-bolts (ISO 6162-2 und ISO 6164) are available on request.

Tools for Parflare machines



- ⚠ Use of worn or non- suitable tooling may result in flange failure and damage of machine
- ⚠ Tools must be checked regularly, at least after 50 assemblies
- ⚠ Worn tools must be replaced
- ⚠ Use only genuine Parker Parts
- ⚠ Tools must always be kept clean and lubricated

Checking instructions for Parflare HPF tools



- Clean pin for checking
- Visual check: Surface must be free of wear and damage



- Clean die halves for checking
- Visual check: Gripping surface must be clean and free of wear
- Use wire brush to remove metal particles from gripping surface

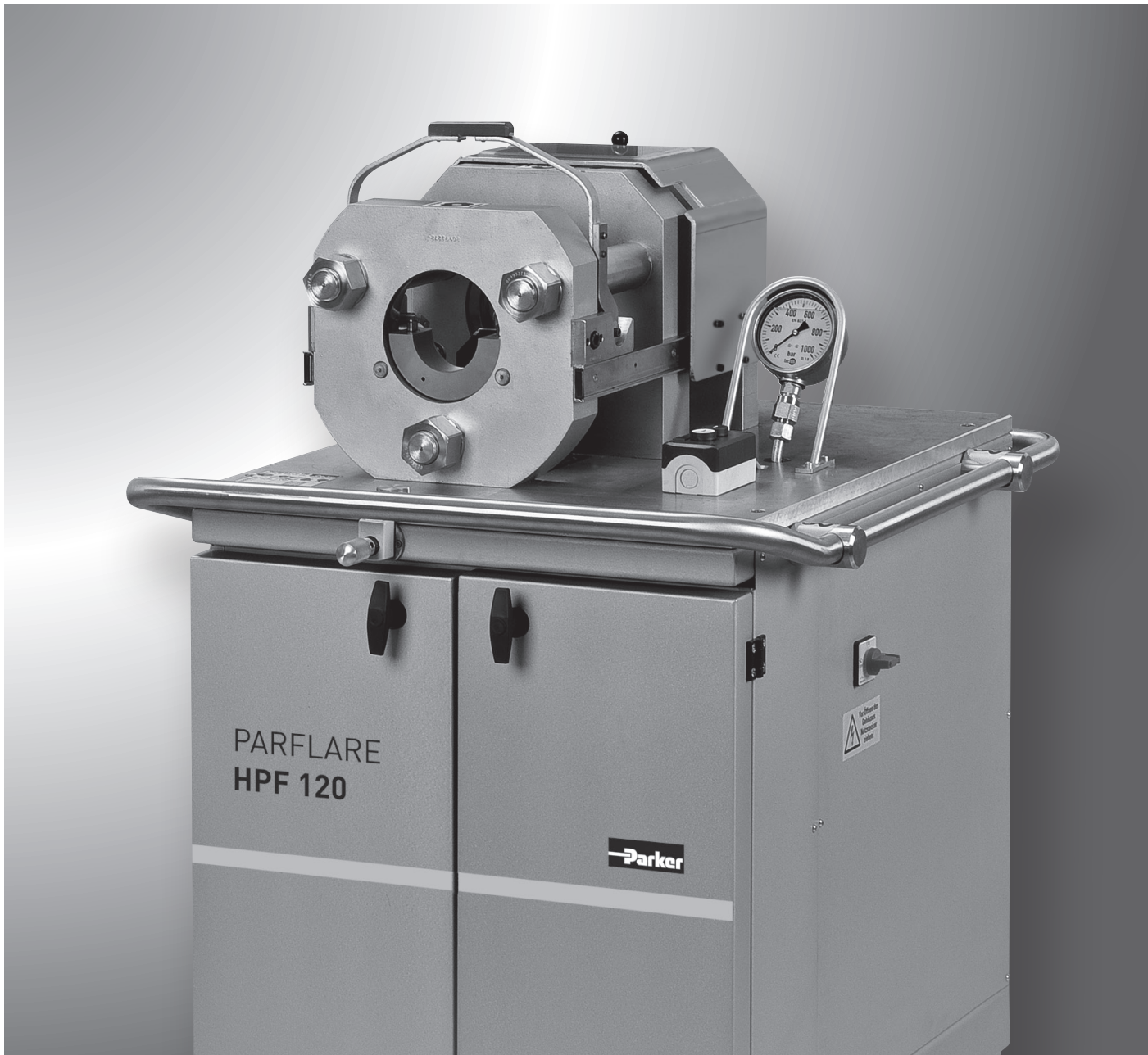

Machines und tooling

ENGINEERING YOUR SUCCESS.

Parflare HPF 120 and 170

Machines for manufacturing HPF flange connections



The Parflare HPF 120

The Parflare HPF 120 and Parflare HPF 170 have been developed for tube end forming by axial pressure operation for the HPF flange system and is a machine for single operation for tube sizes up to 150 mm maximal tube outside diameter (HPF 120 max. 90x9.0 mm; HPF 170 max. 150x15.0 mm)).

Flange flaring is achieved by axial pressure of the tool into the tube end. The flaring contour matches the Parker HPF insert.

The feed movement of the tool is produced by an hydraulic cylinder which is driven by a unit in the machine housing. The return feed is also electro-hydraulic. The tubes are clamped in clamping jaw sets which are clamped by means of a cone. The machine is equipped with an adjustable stop for the tube end. This enables flared flanges to be produced with consistent quality. The split clamping jaws and the tube stop allow simple operation and consistent results. The separation of the clamping jaws and removal of the tubes is made easier by a latch device.

The machine is designed for project work on site.

The Parflare HPF machines are supplied ready to go but tools must be ordered separately. Special clamping jaws and pins are required for each tube size.

Application

- Alternative to conventional welded connections for hydraulic lines
- Machine for project work, on-site assembly and maintenance



The Parflare HPF 170

Parflare HPF 120 and 170

Features, advantages and benefits of Parflare HPF machines

- 1. Cost saving** – Compared to welding or brazing, the flaring process is much less time consuming. Special tube preparation and finishing are not necessary. Energy consumption for flaring is far below the energy needed for brazing or welding.
- 2. Zinc plated tubing** – The Parflare process allows the use of zinc plated tubing. The cost for cleaning post process, or painting can be saved.
- 3. Excellent sealing quality** – The HPF inserts are precisely fitted into the contour of the tube termination. Sealing is achieved by an O-ring.
- 4. Process/Product concept** – Parflare machines are especially designed to match Parker HPF standards. Machines, tools and products are fine tuned for reliable performance.
- 5. Workshop use** – The rigid machine design allows project work in on-site piping workshops.
- 6. Short clamping length** – Clamping dies for HPF flaring are optimised for minimum straight tube length.
- 7. Easy to use** – All operational devices are obvious so that machine operation is intuitive. Insertion and withdrawal of the tube ends are facilitated by the two part clamping jaws.
- 8. Quality** – Consistent quality results are achieved by recommended values for machine setting.
- 9. Constant flare diameter** – The diameter of the flare is given by the tool contour and the tube stop adjustment.
- 10. Flexible** – Different tube material and quality might require special setting of tube stop. For best results, these parameters can be manually adjusted based on operators experience.
- 11. Clean** – The Parflare process is environmentally clean and safe. As no heat or chemicals are used, hazards from fumes or heat do not occur.
- 12. Ready to go** – The Parflare HPF machines are delivered including all necessary items such as tool magazine (HPF 120), electric plug, operator manual, declaration of CE conformity, short instruction pictograms on machine housing and dimensional charts for tube preparation.

Specification

Application	Flaring machine HPF 120	Flaring machine HPF 170
Process	Tube forming by axial pressure	Tube forming by axial pressure
Design	On-site and workshop machine for individual tube preparation. Transportable on wheels	Stationary workshop machine for individual tube preparation
Operation	Manual tube clamping Hydraulic driven tool Process control by setting wheels and pressure display	Manual tube clamping Hydraulic driven tool Process control by setting wheels and pressure display
Tube diameter	25 to 90 mm	97 to 150 mm
Tube material	Steel	Steel
Cycle time	1 - 2 minutes flaring time 3 - 5 minutes total cycle time	1 - 2 minutes flaring time 3 - 5 minutes total cycle time
Tools	Flaring pin BHPF.. Clamping die set MHPF..	Flaring pin BHPF.. Clamping die set MHPF..
Tool lubrication	manual	manual
Lubricant for pin	High pressure grease (e.g. Rivolta WAP)	High pressure grease (e.g. Rivolta WAP)
Machine dimensions (L x W x H)	890 x 800 x 1.307 mm	1200 x 730 x 1.460 mm
Weight	approx. 415 kg	approx. 1.100 kg
Nominal voltage	400 V/3Ph/1.1 kW	400 V/3Ph/2kW
Connecting cable	3m/CEE 16A	3m/CEE 16A
Sound pressure level	Max. 70 dB (A)	Max. 70 dB (A)

Machines and tooling

Parflare HPF 120 and 170

Ordering

Type	Order code HPF 120
Parflare HPF 120 WorkCentre Ready to use, including operating manual, filled with hydraulic oil and lubricant Without tools Basic machine 400V, 3 phase, 50Hz	HPF120EU400V
Catalogue 4167/DE	4167 via Parker catalogue service EMDC
Operating manual UK/DE	HPF120/MANUAL
Type	Order code HPF 170
Parflare HPF 170 Ready to use, including operating manual, filled with hydraulic oil and lubricant Without tools Basic machine 400V, 3 phase, 50Hz	HPF170EU400V
Catalogue 4167/DE	4167 via Parker catalogue service EMDC
Operating manual UK/DE	HPF170/MANUAL

Parflare machines are shipped in special containers which should be kept for future transportation to avoid damage.

Flaring tools for machines: Parflare HPF 120 and 170

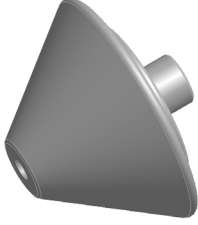
Clamping die set MHPF		Pressure pin BHPF
		
Tube O.D. mm	Order code	Order code
25.0	MHPF25	BHPF25/90
30.0	MHPF30	
38.0	MHPF38	
42.0	MHPF42	
50.0	MHPF50	
60.0	MHPF60	
65.0	MHPF65	
66.0	MHPF66	
73.0	MHPF73	
75.0	MHPF75	
80.0	MHPF80	BHPF90/170
88.0	MHPF88	
90.0	MHPF90	
97.0*	MHPF97	
101.6*	MHPF101.6	
115.0*	MHPF115	
130.0*	MHPF130	
150.0*	MHPF150	

*Only for Parflare HPF 170

Tool lifetime

Assembly tools are subject to wear and must be regularly (max. 50 assemblies) cleaned and checked (for checking instructions see chapter Installation). In advance of each forming the flaring pins should be lubricated with a high pressure grease. Worn tools can cause dangerous assembly failures and must be replaced in time. Maximum lifetime can be achieved by observing the following:

- Regular cleaning and checking
- Clean and corrosion-protected storage
- Proper de-burring and cleaning of tube end
- Proper tool selection and operation
- Use of specified lubricant



HPF – SAE 3000/ISO 6162-1

HPF – Flange

ISO 6162-1 footprint

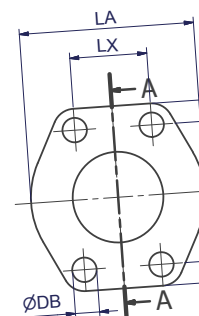
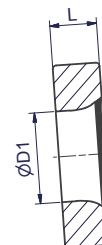
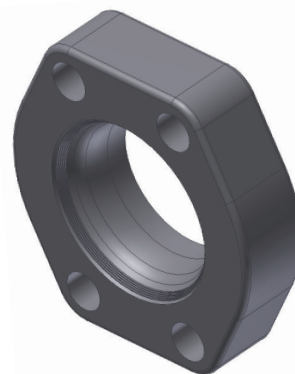

Size Inch	Tube O.D.	Order code	D1	L	LA	LB	LX	LY	DB	Weight (Steel) kg/1 piece
1 1/4	42	HPF320-42CFX	42.5	22	73	79.4	30.2	58.7	11.0	0.5
1 1/2	50	HPF324-50CFX	50.5	25	83	93.8	35.7	69.9	13.0	0.7
2	50	HPF332-50CFX	50.5	26	97	101.6	42.9	77.8	13.5	1.1
2	60	HPF332-60CFX	60.5	26	97	101.6	42.9	77.8	13.5	0.9
2 1/2	60	HPF340-60CFX	60.5	38	109	114.3	50.8	88.9	13.5	2.0
2 1/2	73	HPF340-73CFX	74.0	38	109	114.3	50.8	88.9	13.5	1.5
3	90	HPF348-90CFX	90.5	41	131	135.1	61.9	106.4	17.0	2.3

Pressure ratings (PN) refer to the flanges.
Effective pressure depends on the used tube and operating temperature (page 14-16).

Threaded flanges available on request.

Ordering information/Nomenclature

Ordering information / Part numbering

Order code – HPF

Example: **HPF6 20 -42x3.0 -OR CF**

Part Code	Flange- Type	Flange- Code	Footprint
HPF	3	ISO 6162-1	(SAE 3000)
HPF	6	ISO 6162-2	(SAE 6000)
HPF	4	ISO 6164	Square flange

Series

8	12	16	20	24	32	40	48	64	72	80
1/2"	3/4"	1"	1 1/4"	1 1/2"	2"	2 1/2"	3"	4"	4 1/2"	5"

Pipe size

42x3.0 / Pipe O.D. x wall thicknes (mm)

Sealing system

OR O-Ring-Seal (NBR)
 VIT O-Ring-Seal (FKM)
 V F37-Seal
 F Flat Face

Material and coating

CF Steel, Cr(VI)-free

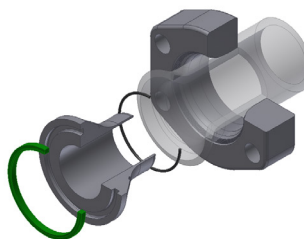

Ordering example for a tube to port flange connection:

Parts (Connection kit*)	Component	Qty.	Code	Material
HPF620-38X6.0-ORCF	Flange	1	HPF620-38CFX	Steel, Cr(VI)-free
Tube to port connection	Insert	1	IP620-38X6.0-ORCF	Steel, Cr(VI)-free
1 1/4" 6000psi footprint	O-Ring (included in insert)	1	OR37.69X3.53X	NBR, 90° Shore A
38X6.0 Tube	O-Ring (included in insert)	1	OR29.87X1.78X	NBR, 90° Shore A
HPF448-80X10.0-VCF	Flange	1	HPF448-80CFX	Steel, Cr(VI)-free
Tube to port connection	Insert	1	IP448-80X10.0-VCF	Steel, Cr(VI)-free
3" ISO 6164 footprint	F37-Profile seal (included in insert)	1	F37S448X	PUR, P5008
80X10.0 Tube	O-Ring (included in insert)	1	OR69.57X1.78X	NBR, 90° Shore A

*Bolts not included in kit. Bolts see page 42, 52, 62.



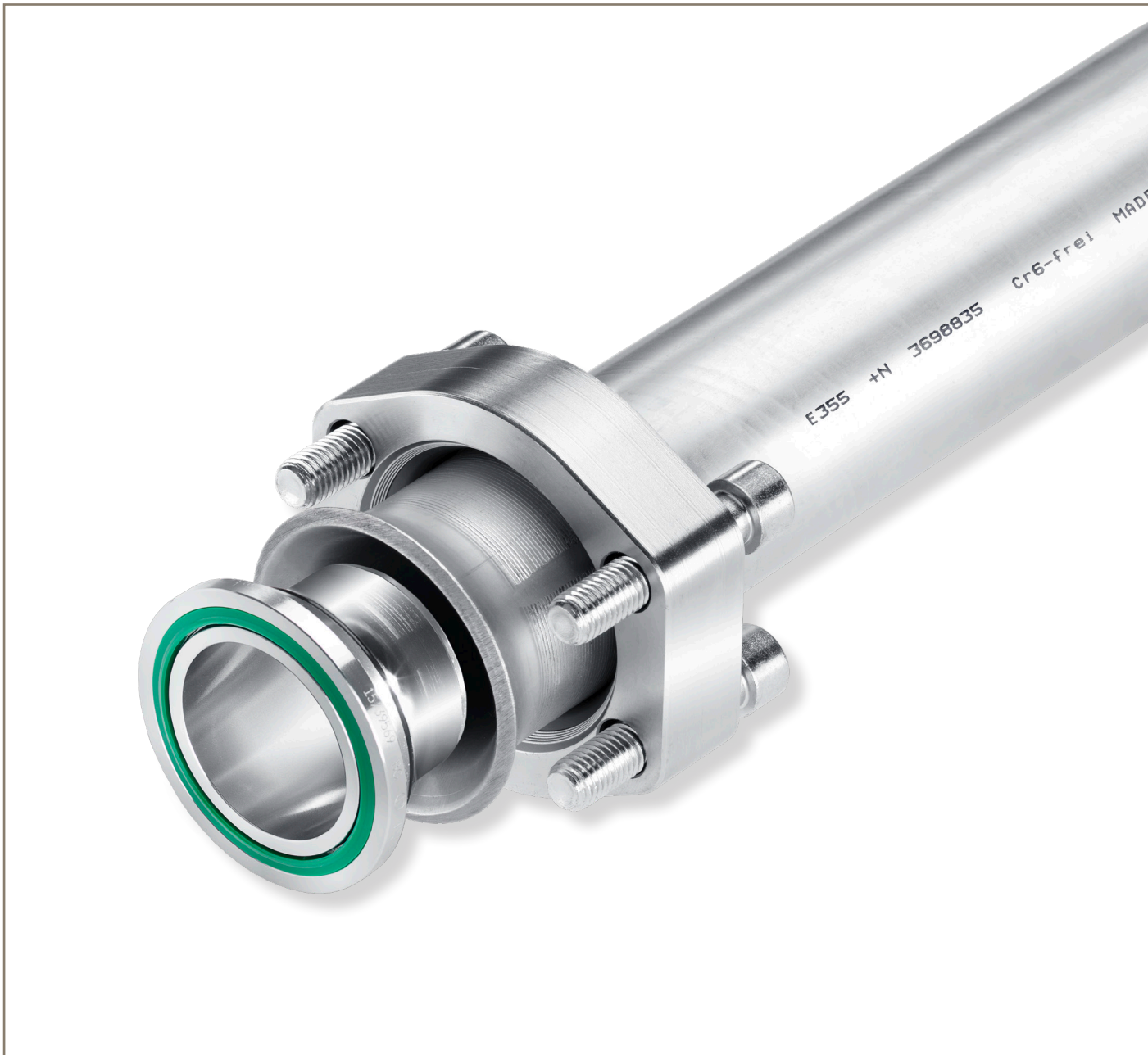

HPF - SAE 3000/ISO 6162-1

ENGINEERING YOUR SUCCESS.

HPF – Flange

ISO 6162-1 footprint

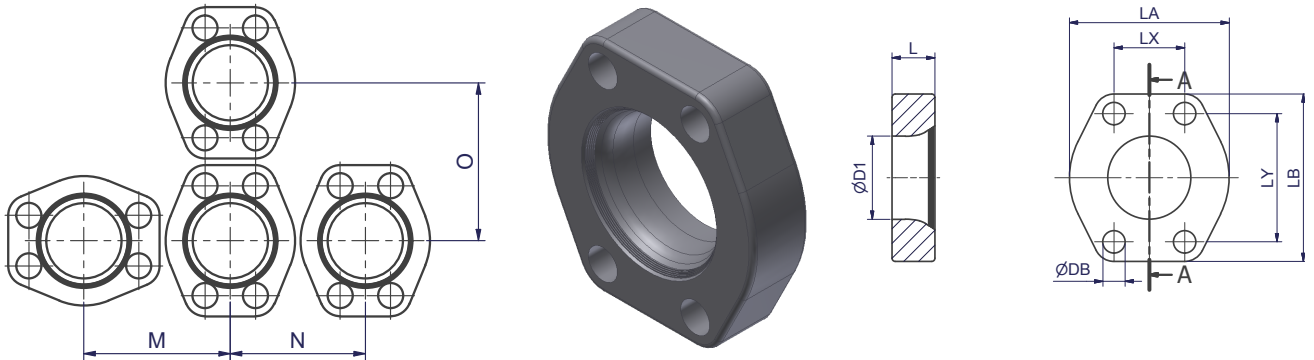

Size Inch	Tube O.D.	Order code	D1	L	LA	LB	LX	LY	DB	M	N	O	Weight (Steel) kg/1 piece	PN (bar)
1 1/4	42	HPF320-42CFX	42.5	22	73	79.4	30.2	58.7	11.0	81	78	84	0.5	280
1 1/2	50	HPF324-50CFX	50.5	25	83	93.8	35.7	69.9	13.0	93	87	99	0.7	280
2	50	HPF332-50CFX	50.5	26	97	101.6	42.9	77.8	13.5	104	102	107	1.1	280
2	60	HPF332-60CFX	60.5	26	97	101.6	42.9	77.8	13.5	104	102	107	0.9	280
2 1/2	60	HPF340-60CFX	60.5	38	109	114.3	50.8	88.9	13.5	117	114	120	2.0	210
2 1/2	73	HPF340-73CFX	74.0	38	109	114.3	50.8	88.9	13.5	117	114	120	1.5	210
3	90	HPF348-90CFX	90.5	41	131	135.1	61.9	106.4	17.0	138	136	141	2.3	210

Pressure ratings (PN) refer to the flanges.
 Effective pressure depends on the used tube and operating temperature (page 14-16).

Order code		
Part and Material	Suffix surface and material	Example
Flange: Steel, zinc plated, Cr(VI)-free	CFX	HPF320-42CFX



IPV – Insert with F37 profile seal

ISO 6162-1 footprint

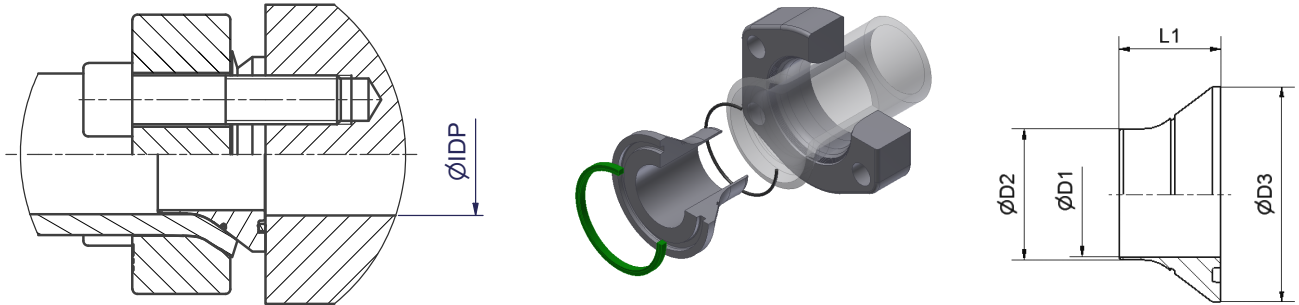

Size Inch	Tube	Complete part (flange incl. insert and seals)	Insert (incl. seals)	D1	D2	D3	L1	IDP (inner- \varnothing of the port)	Weight (Steel) kg/1 piece	F37 seal (face seal)*	Alternative O-Ring (face seal)*	O-Ring (tube seal)
1 1/4	42x4.0	HPF320-42X4.0-VCF	IP320-42X4.0-VCF	30.5	33.4	50.8	34	30	0.11	F37S20X	OR37.7X3.53X	OR37.82X1.78X
1 1/2	50x5.0	HPF324-50X5.0-VCF	IP324-50X5.0-VCF	36.5	39.4	60.4	39	38	0.19	F37S24X	OR47.22X3.53X	OR47.37X1.78X
1 1/2	50x6.0	HPF324-50X6.0-VCF	IP324-50X6.0-VCF	34.5	37.2	60.4	40	38	0.20	F37S24X	OR47.22X3.53X	OR47.37X1.78X
2	50x5.0	HPF332-50X5.0-VCF	IP332-50X5.0-VCF	36.5	39.4	71.4	46	48	0.36	F37S32X	OR56.75X3.53X	OR50.52X1.78X
2	60x5.0	HPF332-60X5.0-VCF	IP332-60X5.0-VCF	46.5	49.4	71.4	38	48	0.25	F37S32X	OR56.75X3.53X	OR56.87X1.78X
2	60x6.0	HPF332-60X6.0-VCF	IP332-60X6.0-VCF	44.3	47.3	71.4	38	48	0.25	F37S32X	OR56.75X3.53X	OR56.87X1.78X
2 1/2	60x6.0	HPF340-60X6.0-VCF	IP340-60X6.0-VCF	44.3	47.3	84.1	47	60	0.49	F37S40X	OR69.44X3.53X	OR56.87X1.78X
2 1/2	73x7.0	HPF340-73X7.0-VCF	IP340-73X7.0-VCF	55.2	58.2	84.1	40	60	0.35	F37S40X	OR69.44X3.53X	OR66.40X1.78X
3	90x5.0	HPF348-90X5.0-VCF	IP348-90X5.0-VCF	76.5	79.4	101.6	38	73	0.39	F37S48X	OR85.32X3.53X	OR88.62X1.78X
3	90x9.0	HPF348-90X9.0-VCF	IP348-90X9.0-VCF	68.5	71.4	101.6	43	73	0.54	F37S48X	OR85.32X3.53X	OR82.27X1.78X

Insert IP...ORCF with NBR O-Ring seal alternative to F37 seal.

*Face seals are designed for the corresponding IDP. Inserts for bigger IDP on request.

Order code		
Part and Material	Suffix surface and material	Example
Insert: Steel, zinc plated, Cr(VI)-free F37 seal: PUR O-Ring: NBR	VCF	IP320-42X4.0-VCF
Insert: Steel, zinc plated, Cr(VI)-free O-Ring: NBR	ORCF	IP320-42X4.0-ORCF

IPF – Insert with flat face

ISO 6162-1 footprint

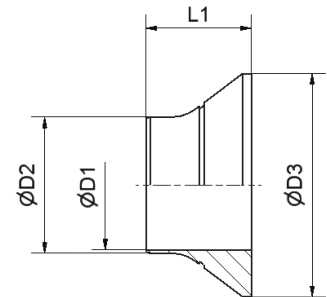
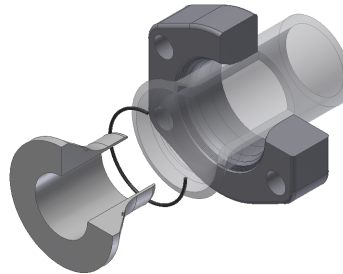

Size Inch	Tube	Complete part (flange incl. insert and seals)	Insert (incl. seals)	D1	D2	D3	L1	Weight (Steel) kg/1 piece	O-Ring
1 1/4	42x4.0	HPF320-42X4.0-FCF	IP320-42X4.0-FCF	30.5	33.4	50.8	34	0.13	OR37.82X1.78X
1 1/2	50x5.0	HPF324-50X5.0-FCF	IP324-50X5.0-FCF	36.5	39.4	60.4	39	0.20	OR47.37X1.78X
1 1/2	50x6.0	HPF324-50X6.0-FCF	IP324-50X6.0-FCF	34.5	37.2	60.4	40	0.21	OR47.37X1.78X
2	50x5.0	HPF332-50X5.0-FCF	IP332-50X5.0-FCF	36.5	39.4	71.4	46	0.38	OR50.52X1.78X
2	60x5.0	HPF332-60X5.0-FCF	IP332-60X5.0-FCF	46.5	49.4	71.4	38	0.27	OR56.87X1.78X
2	60x6.0	HPF332-60X6.0-FCF	IP332-60X6.0-FCF	44.3	47.3	71.4	38	0.27	OR56.87X1.78X
2 1/2	60x6.0	HPF340-60X6.0-FCF	IP340-60X6.0-FCF	44.3	47.3	84.1	47	0.51	OR56.87X1.78X
2 1/2	73x7.0	HPF340-73X7.0-FCF	IP340-73X7.0-FCF	55.2	58.2	84.1	40	0.37	OR66.40X1.78X
3	90x5.0	HPF348-90X5.0-FCF	IP348-90X5.0-FCF	76.5	79.4	101.6	38	0.41	OR88.62X1.78X
3	90x9.0	HPF348-90X9.0-FCF	IP348-90X9.0-FCF	68.5	71.4	101.6	43	0.57	OR82.27X1.78X

Order code		
Part and Material	Suffix surface and material	Example
Insert: Steel, zinc plated, Cr(VI)-free O-Ring: NBR	FCF	IP320-42X4.0-FCF



HPF-FB90 – 90° Flange bend

ISO 6162-1 footprint

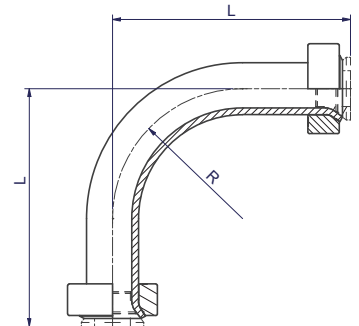

Size Inch	Tube	Complete Part Order code (Flanges and flared tube bend)	L	R
1 1/4	42x4.0	HPF320-42X4.0FB90CF*	200	105
1 1/2	50x6.0	HPF324-50X6.0FB90CF*	240	125
2	60x6.0	HPF332-60X6.0FB90CF*	290	150
2 1/2	73x7.0	HPF340-73X7.0FB90S	350	183
3	90x9.0	HPF348-90X9.0FB90S	430	225

Inserts not included

Other sizes on request.

*All parts (tube and flange) in zinc plated steel, Cr(VI)-free

HPF-FB45 – 45° Flange bend

ISO 6162-1 footprint

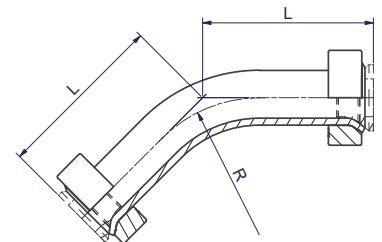

Size Inch	Tube	Complete Part Order code (Flanges and flared tube bend)	L	R
1 1/4	42x4.0	HPF320-42X4.0FB45CF*	140	105
1 1/2	50x6.0	HPF324-50X6.0FB45CF*	170	125
2	60x6.0	HPF332-60X6.0FB45CF*	200	150
2 1/2	73x7.0	HPF340-73X7.0FB45S	250	183
3	90x9.0	HPF348-90X9.0FB45S	290	225

Inserts not included

Other sizes on request.

*All parts (tube and flange) in zinc plated steel, Cr(VI)-free

Order code		
Part and Material	Suffix surface and material	Example
Phosphated steel tube with zinc plated steel flange, Cr(VI)-free	S	HPF320-42X4-0FB90S

ENGINEERING YOUR SUCCESS.

LB - Flange L-block

ISO 6162-1 footprint

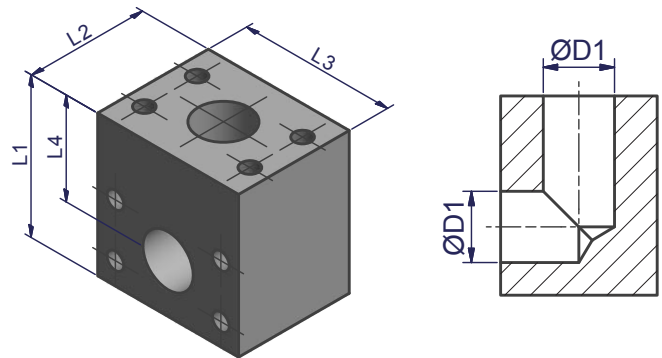

Size Inch	Order code	D1	L1	L2	L3	L4	Weight (Steel) kg/1 piece.
1 1/4	LB320CFX	30.0	80.0	58.0	80.0	51.0	2.4
1 1/2	LB324CFX	38.0	90.0	68.0	90.0	56.0	3.4
2	LB332CFX	48.0	96.0	78.0	100.0	57.0	4.4
2 1/2	LB340CFX	60.0	110.0	88.0	110.0	65.0	6.0
3	LB348CFX	73.0	135.0	110.0	135.0	80.0	11.3

Other sizes on request

LBR - Flange L-block reducer

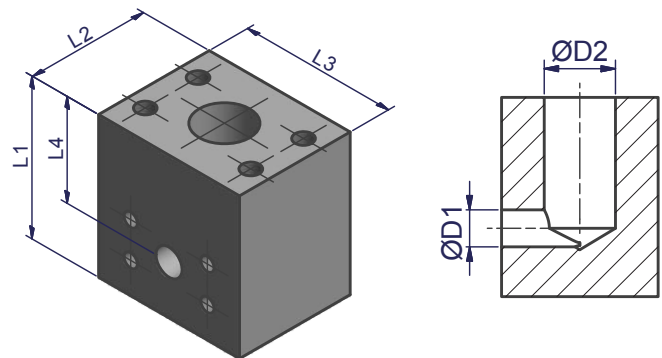

Size Inch	Order code	D1	D2	L1	L2	L3	L4	Weight (Steel) kg/1 piece.
1 1/2 - 1 1/4	LBR324-320CFX	30.0	38.0	90.0	68.0	90.0	56.0	3.6
2 - 1 1/4	LBR332-320CFX	30.0	48.0	96.0	78.0	100.0	57.0	4.7
2 - 1 1/2	LBR332-324CFX	38.0	48.0	96.0	78.0	100.0	57.0	4.6
2 1/2 - 1 1/2	LBR340-324CFX	38.0	60.0	110.0	88.0	110.0	65.0	6.5
2 1/2 - 2	LBR340-332CFX	48.0	60.0	110.0	88.0	110.0	65.0	6.3
3 - 2	LBR348-332CFX	48.0	73.0	135.0	110.0	135.0	80.0	11.9
3 - 2 1/2	LBR348-340CFX	60.0	73.0	135.0	110.0	135.0	80.0	11.6

Other sizes on request

Order code			
Material	Suffix surface and material	Example Flange L-block	Example Flange L-block reducer
Steel, zinc plated, Cr(VI)-free	CFX	LB324CFX	LBR324-320CFX
Steel, oiled	SX	LB324SX	LBR324-320SX



TB - Flange T-block

ISO 6162-1 footprint

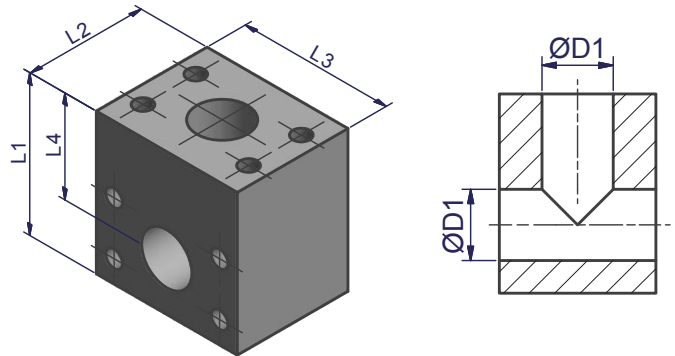

Size Inch	Order code	D1	L1	L2	L3	L4	Weight (Steel) kg/1 piece
1 1/4	TB320CFX	30.0	80.0	58.0	80.0	51.0	2.2
1 1/2	TB324CFX	38.0	90.0	68.0	90.0	56.0	3.1
2	TB332CFX	48.0	96.0	78.0	100.0	57.0	3.9
2 1/2	TB340CFX	60.0	110.0	88.0	110.0	65.0	5.3
3	TB348CFX	73.0	135.0	110.0	135.0	80.0	10.0

Other sizes on request

TBR - Flange T-block reducer

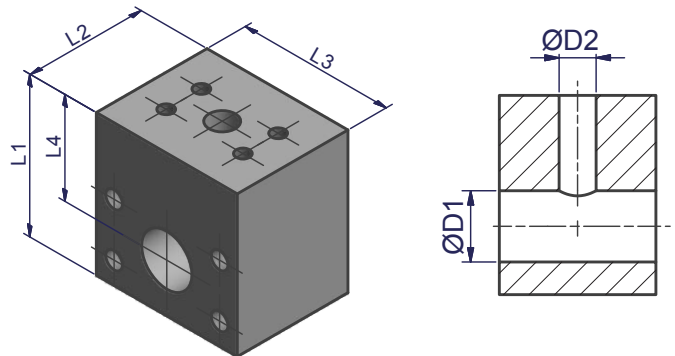

Size Inch	Order code	D1	D2	L1	L2	L3	L4	Weight (Steel) kg/1 piece
1 1/2 - 1 1/4 - 1 1/2	TBR324-320-324CFX	38.0	30.0	90.0	68.0	90.0	56.0	3.3
2 - 1 1/4 - 2	TBR332-320-332CFX	48.0	30.0	96.0	78.0	100.0	57.0	4.3
2 - 1 1/2 - 2	TBR332-324-332CFX	48.0	38.0	96.0	78.0	100.0	57.0	4.2
2 1/2 - 1 1/2 - 2 1/2	TBR340-324-340CFX	60.0	38.0	110.0	88.0	110.0	65.0	5.9
2 1/2 - 2 - 2 1/2	TBR340-332-340CFX	60.0	48.0	110.0	88.0	110.0	65.0	5.6
3 - 2 - 3	TBR348-332-348CFX	73.0	48.0	135.0	110.0	135.0	80.0	11.0
3 - 2 1/2 - 3	TBR348-340-348CFX	73.0	60.0	135.0	110.0	135.0	80.0	10.6

Other sizes on request

Order code			
Material	Suffix surface and material	Example Flange T-block	Example Flange T-block reducer
Steel, zinc plated, Cr(VI)-free	CFX	TB324CFX	TBR324-320-324CFX
Steel, oiled	SX	TB324SX	TBR324-320-324SX

ENGINEERING YOUR SUCCESS.

Bolts and nuts

HPF ISO 6162-1 footprint



Size Inch	Tube	Connection Tube to Tube				Connection Tube to Port	
		Flange with through-hole – Flange with through-hole					
		Bolts ISO 4762 10.9 (DIN 912)		Nuts ISO 4032 10		Bolts ISO 4762 10.9 (DIN 912)	
		Description	Order code	Description	Order code	Description	Order code
1 1/4	42x4.0	M10x80	ZYLS10X80109ZNFLX	M10	ISO4032-M10-10ZNFLX	M10x45	ZYLS10X45109ZNFLX
1 1/2	50x5.0	M12x90	ZYLS12X90109ZNFLX	M12	ISO4032-M12-10ZNFLX	M12x55	ZYLS12X55109ZNFLX
1 1/2	50x6.0	M12x90	ZYLS12X90109ZNFLX	M12	ISO4032-M12-10ZNFLX	M12x55	ZYLS12X55109ZNFLX
2	50x5.0	M12x110	ZYLS12X110109ZNFLX	M12	ISO4032-M12-10ZNFLX	M12x65	ZYLS12X65109ZNFLX
2	60x5.0	M12x100	ZYLS12X100109ZNFLX	M12	ISO4032-M12-10ZNFLX	M12x55	ZYLS12X55109ZNFLX
2	60x6.0	M12x100	ZYLS12X100109ZNFLX	M12	ISO4032-M12-10ZNFLX	M12x55	ZYLS12X55109ZNFLX
2 1/2	60x6.0	M12x140	ZYLS12X140109ZNFLX	M12	ISO4032-M12-10ZNFLX	M12x80	ZYLS12X80109ZNFLX
2 1/2	73x7.0	M12x130	ZYLS12X130109ZNFLX	M12	ISO4032-M12-10ZNFLX	M12x70	ZYLS12X70109ZNFLX
3	90x5.0	M16x130	ZYLS16X130109ZNFLX	M16	ISO4032-M16-10ZNFLX	M16x80	ZYLS16X80109ZNFLX
3	90x9.0	M16x140	ZYLS16X140109ZNFLX	M16	ISO4032-M16-10ZNFLX	M16x80	ZYLS16X80109ZNFLX

Order code		
Part and Material	Suffix surface and material	Example
Bolt: Steel, grade 10.9, zinc flaked	ZNFLX	ZYLS10X70109ZNFLX
Nut: Steel, grade 10.9, zinc flaked	ZNFLX	ISO4032-M10-10ZNFLX



KH – Ball valve drilled and tapped for SAE 3000 and SAE 6000 Flanges

SAE 3000/ISO 6162-1

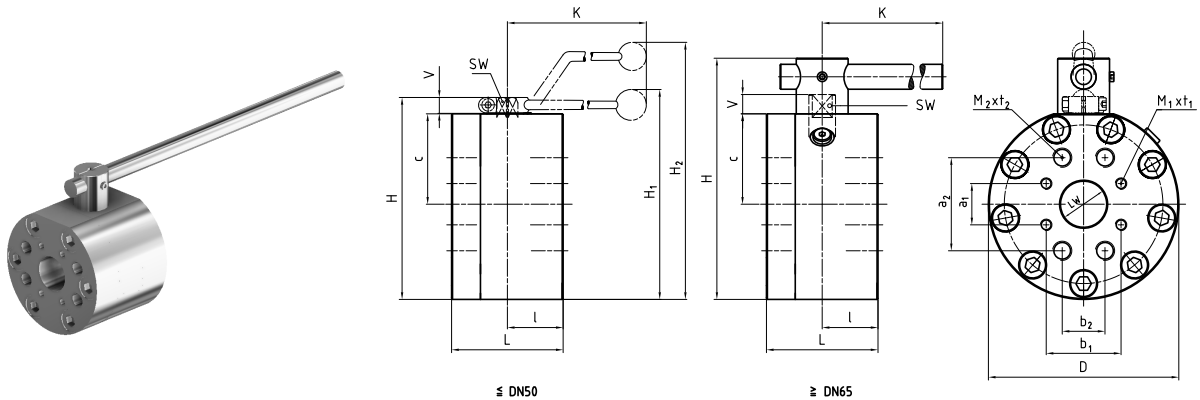

Material Steel

Size Inch	Order Code	DN	LW	L	I	D	H	c	V	K	SW	SAE 3000 boring pattern				SAE 6000 boring pattern				H1	H2	Material Code	Lever	Weight kg	W.P. (bar)
												a1	b1	M1	t1	a2	b2	M2	t2						
1 1/4	KH20-32CF*	32	32	100	50	145	158	68.0	17	306	17	30.2	58.7	M10	20	66.7	31.8	M12	22	-	232	212A	St	11.70	280 / 420
1 1/4	KH20-32TM1214CF*	32	32	100	50	145	158	68.0	17	306	17	30.2	58.7	M12	20	66.7	31.8	M14	22	-	232	212A	St	11.65	210 / 400
1 1/2	KH24-38CF	40	38	110	55	165	178	78.0	17	306	17	35.7	69.9	M12	20	79.4	36.5	M16	27	-	252	212A	St	17.10	210 / 420
2	KH32-48CF	50	48	116	58	198	210	94.0	17	306	17	42.9	77.8	M12	20	96.8	44.5	M20	28	-	284	212A	St	24.60	210 / 420
2 1/2	KH40-63CF	65	63	170	75	218	275	100.0	20	600	16	88.9	50.8	M12	19	58.7	123.8	M24	41	-	-	282A	St	44.40	175 / 420
3	KH48-76CF	80	76	170	79	258	315	115.0	26	600	19	106.4	61.9	M16	24	71.4	152.4	M30	47	-	-	282A	St	54.90	160 / 420

*Please choose between KH20-32CF and KH20-32TM1214CF according to needed connection threads M1 and M2.
Steel ball valves 1/2" up to 3" with SAE 3000 and SAE 6000 boring pattern.
The bore pattern for 2 1/2" and 3" is turned to 90°.

Order code		
Material	Suffix surface and material	Example
Steel, zinc plated, Cr(VI)-free	CF	KH20-32CF

	Material 212A	Material 282A
Body	Steel	Steel
Ball	Steel	Steel
Stem	Steel	Stainless Steel
Ball seats	POM	POM
O-Ring	NBR	NBR
Tmin / T max	-10°C / 100°C	-10°C / 100°C



HPF – SAE 6000/ISO 6162-2

ENGINEERING YOUR SUCCESS.

HPF – Flange

ISO 6162-2 footprint

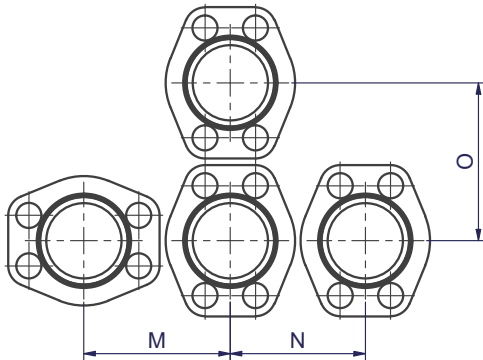

One Piece Design

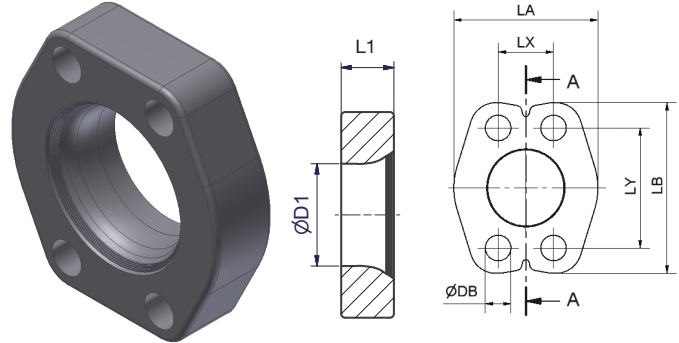

Size Inch	Tube O.D.	Order code	D1	L1	LA	LB	LX	LY	DB	M	N	O	Weight (Steel) kg/1 piece	PN (bar)
3/4	25	HPF612-25CFX	25.4	24	60.5	71.4	23.8	50.8	10.6	70	65	76	0.5	420
1	30	HPF616-30CFX	30.4	24	69.9	81.0	27.8	57.2	13.3	80	75	86	0.5	420
1	38	HPF616-38CFX	38.4	24	69.9	81.0	27.8	57.2	13.3	80	75	86	0.5	420
1 1/4	38	HPF620-38CFX	38.4	30	77.7	95.3	31.8	66.7	15.0	91	83	100	1.0	420
1 1/4	38	HPF620-38H12CFX	38.4	30	77.7	95.3	31.8	66.7	13.3	91	83	100	1.1	420
1 1/4	42	HPF620-42CFX	42.5	30	77.7	95.3	31.8	66.7	15.0	91	83	100	0.9	420
1 1/4	42	HPF620-42H12CFX	42.5	30	77.7	95.3	31.8	66.7	13.3	91	83	100	1.0	420
1 1/2	38	HPF624-38CFX	38.5	35	95.3	112.8	36.5	79.4	16.7	109	100	118	1.7	420
1 1/2	50	HPF624-50CFX	50.5	35	95.3	112.8	36.5	79.4	16.7	109	100	118	1.5	420
2	50	HPF632-50CFX	50.4	40	114.3	133.4	44.5	96.8	20.6	129	119	139	2.9	420
2	60	HPF632-60CFX	60.5	40	114.3	133.4	44.5	96.8	20.6	129	119	139	2.4	420
2	65	HPF632-65CFX	65.5	40	114.3	133.4	44.5	96.8	20.6	129	119	139	2.3	420
2	66	HPF632-66CFX	66.5	40	114.3	133.4	44.5	96.8	20.6	129	119	139	2.3	420
2 1/2	75	HPF640-75CFX	76.0	50	150.0	176.0	58.7	123.8	25.0	169	156	183	5.3	420
2 1/2	80	HPF640-80CFX	81.0	50	150.0	176.0	58.7	123.8	25.0	169	156	183	5.1	420
3	97	HPF648-97CFX	98.0	52	176.0	212.0	71.4	152.4	32.0	202	184	218	8.4	420

Pressure ratings (PN) refer to the flanges.
Effective pressure depends on the used tube and operating temperature (page 14-16).

Order code		
Part and Material	Suffix surface and material	Example
Flange: Steel, zinc plated, Cr(VI)-free	CFX	HPF632-66CFX



IPV – Insert with F37-Profile seal

ISO 6162-2 footprint

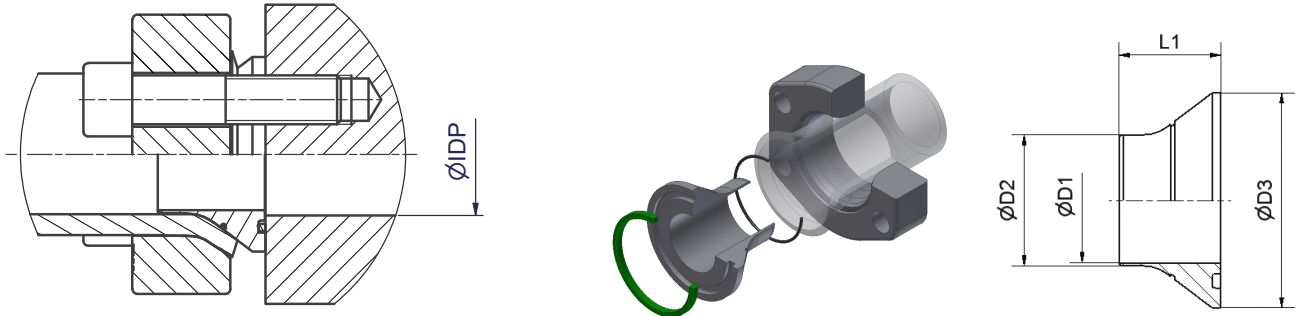

Size Inch	Tube	Complete part (flange incl. insert and seal)	Insert (incl. seals)	D1	D2	D3	L1	IDP (inner-Ø of the port)	Weight (Steel) kg/1 piece	F37 seal (face seal)*	Alternative O-Ring (face seal)*	O-Ring (tube seal)
3/4	25x3.0	HPF612-25X3.0-VCF	IP612-25X3.0-VCF	15.5	18.5	41.5	38	19	0.11	F37S12X	OR25X3.53X	OR25.12X1.78X
3/4	25x4.0	HPF612-25X4.0-VCF	IP612-25X4.0-VCF	13.5	16.5	41.5	39	19	0.11	F37S12X	OR25X3.53X	OR23.52X1.78X
1	30x4.0	HPF616-30X4.0-VCF	IP616-30X4.0-VCF	18.5	21.5	47.5	40	25	0.15	F37S16X	OR32.92X3.53X	OR28.3X1.78X
1	30x5.0	HPF616-30X5.0-VCF	IP616-30X5.0-VCF	16.5	19.5	47.5	41	25	0.16	F37S16X	OR32.92X3.53X	OR26.7X1.78X
1	38x4.0	HPF616-38X4.0-VCF	IP616-38X4.0-VCF	26.5	29.5	47.5	35	25	0.11	F37S16X	OR32.92X3.53X	OR36.27X1.78X
1	38x6.0	HPF616-38X6.0-VCF	IP616-38X6.0-VCF	22.5	25.5	47.5	37	25	0.13	F37S16X	OR32.92X3.53X	OR29.87X1.78X
1 1/4	38x4.0	HPF620-38X4.0-VCF	IP620-38X4.0-VCF	26.5	29.5	54.0	39	30	0.18	F37S20X	OR37.7X3.53X	OR36.27X1.78X
1 1/4	38x4.0	HPF620-38X4.0H12-VCF	IP620-38X4.0-VCF	26.5	29.5	54.0	39	30	0.18	F37S20X	OR37.7X3.53X	OR36.27X1.78X
1 1/4	38x5.0	HPF620-38X5.0-VCF	IP620-38X5.0-VCF	24.5	27.5	54.0	40	30	0.19	F37S20X	OR37.7X3.53X	OR34.65X1.78X
1 1/4	38x5.0	HPF620-38X5.0H12-VCF	IP620-38X5.0-VCF	24.5	27.5	54.0	40	30	0.19	F37S20X	OR37.7X3.53X	OR34.65X1.78X
1 1/4	38x6.0	HPF620-38X6.0-VCF	IP620-38X6.0-VCF	22.5	25.5	54.0	42	30	0.21	F37S20X	OR37.7X3.53X	OR29.87X1.78X
1 1/4	38x6.0	HPF620-38X6.0H12-VCF	IP620-38X6.0-VCF	22.5	25.5	54.0	42	30	0.21	F37S20X	OR37.7X3.53X	OR29.87X1.78X
1 1/4	42x5.0	HPF620-42X5.0-VCF	IP620-42X5.0-VCF	28.5	31.5	54.0	38	30	0.17	F37S20X	OR37.7X3.53X	OR37.82X1.78X
1 1/4	42x5.0	HPF620-42X5.0H12-VCF	IP620-42X5.0-VCF	28.5	31.5	54.0	38	30	0.17	F37S20X	OR37.7X3.53X	OR37.82X1.78X
1 1/2	38x5.0	HPF624-38X5.0-VCF	IP624-38X5.0-VCF	24.4	27.4	63.5	47	38	0.33	F37S24X	OR47.22X3.53X	OR34.65X1.78X
1 1/2	50x3.0	HPF624-50X3.0-VCF	IP624-50X3.0-VCF	40.5	43.5	63.5	38	38	0.19	F37S24X	OR47.22X3.53X	OR50.52X1.78X
1 1/2	50x5.0	HPF624-50X5.0-VCF	IP624-50X5.0-VCF	36.5	39.5	63.5	40	38	0.21	F37S24X	OR47.22X3.53X	OR50.52X1.78X
1 1/2	50x6.0	HPF624-50X6.0-VCF	IP624-50X6.0-VCF	34.5	37.5	63.5	42	38	0.24	F37S24X	OR47.22X3.53X	OR47.37X1.78X
1 1/2	50x8.0	HPF624-50X8.0-VCF	IP624-50X8.0-VCF	30.5	33.5	63.5	42	38	0.27	F37S24X	OR47.22X3.53X	OR44.17X1.78X
2	50x5.0	HPF632-50X5.0-VCF	IP632-50X5.0-VCF	36.5	39.4	79.4	51	48	0.53	F37S32X	OR56.75X3.53X	OR50.52X1.78X
2	50x6.0	HPF632-50X6.0-VCF	IP632-50X6.0-VCF	34.5	37.2	79.4	53	48	0.57	F37S32X	OR56.75X3.53X	OR47.37X1.78X
2	50x8.0	HPF632-50X8.0-VCF	IP632-50X8.0-VCF	30.5	33.4	79.4	53	48	0.61	F37S32X	OR56.75X3.53X	OR44.17X1.78X
2	60x6.0	HPF632-60X6.0-VCF	IP632-60X6.0-VCF	44.3	47.3	79.4	44	48	0.42	F37S32X	OR56.75X3.53X	OR56.87X1.78X
2	60x8.0	HPF632-60X8.0-VCF	IP632-60X8.0-VCF	40.5	43.5	79.4	47	48	0.49	F37S32X	OR56.75X3.53X	OR53.7X1.78X
2	65x8.0	HPF632-65X8.0-VCF	IP632-65X8.0-VCF	45.5	48.0	79.4	44	48	0.42	F37S32X	OR56.75X3.53X	OR56.87X1.78X
2	66x8.5	HPF632-66X8.5-VCF	IP632-66X8.5-VCF	45.5	48.2	79.4	44	48	0.42	F37S32X	OR56.75X3.53X	OR56.87X1.78X
2 1/2	75x12.5	HPF640-75X12.5-VCF	IP640-75X12.5-VCF	46.1	49.1	107.7	62	60	1.31	F37S40X	OR69.44X3.53X	OR56.87X1.78X
2 1/2	80x10.0	HPF640-80X10.0-VCF	IP640-80X10.0-VCF	56.4	59.4	107.7	55	60	1.06	F37S40X	OR69.44X3.53X	OR69.57X1.78X
3	97x12.0	HPF648-97X12.0-VCF	IP648-97X12.0-VCF	69.4	72.4	131.7	65	73	1.93	F37S48X	OR85.32X3.53X	OR82.28X1.78X

Insert IP...ORCF with NBR O-Ring seal alternative to F37 seal.

*Face seals are designed for the corresponding IDP. Inserts for bigger IDP on request.

Order code		
Part and Material	Suffix surface and material	Example
Insert: Steel, zinc plated, Cr(VI)-free F37 seal: PUR O-Ring: NBR	VCF	IP612-25X3.0-VCF
Insert: Steel, zinc plated, Cr(VI)-free O-Ring: NBR	ORCF	IP612-25X3.0-ORCF

IPF – Insert with flat face

ISO 6162-2 footprint

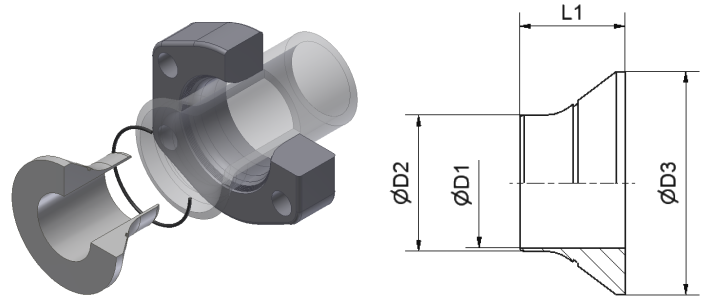

Size Inch	Tube	Complete part (flange incl. insert and seal)	Insert (incl. seals)	D1	D2	D3	L1	Weight (Steel) kg/1 piece	O-Ring
3/4	25x3.0	HPF612-25X3.0-FCF	IP612-25X3.0-FCF	15.5	18.5	41.5	38	0.11	OR25.12X1.78X
3/4	25x4.0	HPF612-25X4.0-FCF	IP612-25X4.0-FCF	13.5	16.5	41.5	39	0.11	OR23.52X1.78X
1	30x4.0	HPF616-30X4.0-FCF	IP616-30X4.0-FCF	18.5	21.5	47.5	40	0.15	OR28.3X1.78X
1	30x5.0	HPF616-30X5.0-FCF	IP616-30X5.0-FCF	16.5	19.5	47.5	41	0.16	OR26.7X1.78X
1	38x4.0	HPF616-38X4.0-FCF	IP616-38X4.0-FCF	26.5	29.5	47.5	35	0.11	OR36.27X1.78X
1	38x6.0	HPF616-38X6.0-FCF	IP616-38X6.0-FCF	22.5	25.5	47.5	37	0.13	OR29.87X1.78X
1 1/4	38x4.0	HPF620-38X4.0-FCF	IP620-38X4.0-FCF	26.5	29.5	54.0	39	0.18	OR36.27X1.78X
1 1/4	38x4.0	HPF620-38X4.0H12-FCF	IP620-38X4.0-FCF	26.5	29.5	54.0	39	0.18	OR36.27X1.78X
1 1/4	38x5.0	HPF620-38X5.0-FCF	IP620-38X5.0-FCF	24.5	27.5	54.0	40	0.19	OR34.65X1.78X
1 1/4	38x5.0	HPF620-38X5.0H12-FCF	IP620-38X5.0-FCF	24.5	27.5	54.0	40	0.19	OR34.65X1.78X
1 1/4	38x6.0	HPF620-38X6.0-FCF	IP620-38X6.0-FCF	22.5	25.5	54.0	42	0.21	OR29.87X1.78X
1 1/4	38x6.0	HPF620-38X6.0H12-FCF	IP620-38X6.0-FCF	22.5	25.5	54.0	42	0.21	OR29.87X1.78X
1 1/4	42x5.0	HPF620-42X5.0-FCF	IP620-42X5.0-FCF	28.5	31.5	54.0	38	0.17	OR37.82X1.78X
1 1/4	42x5.0	HPF620-42X5.0H12-FCF	IP620-42X5.0-FCF	28.5	31.5	54.0	38	0.17	OR37.82X1.78X
1 1/2	38x5.0	HPF624-38X5.0-FCF	IP624-38X5.0-FCF	24.4	27.4	63.5	47	0.35	OR34.65X1.78X
1 1/2	50x3.0	HPF624-50X3.0-FCF	IP624-50X3.0-FCF	40.5	43.5	63.5	38	0.19	OR50.52X1.78X
1 1/2	50x5.0	HPF624-50X5.0-FCF	IP624-50X5.0-FCF	36.5	39.5	63.5	40	0.21	OR50.52X1.78X
1 1/2	50x6.0	HPF624-50X6.0-FCF	IP624-50X6.0-FCF	34.5	37.5	63.5	42	0.24	OR47.37X1.78X
1 1/2	50x8.0	HPF624-50X8.0-FCF	IP624-50X8.0-FCF	30.5	33.5	63.5	42	0.27	OR44.17X1.78X
2	50x5.0	HPF632-50X5.0-FCF	IP632-50X5.0-FCF	36.5	39.4	79.4	51	0.55	OR50.52X1.78X
2	50x6.0	HPF632-50X6.0-FCF	IP632-50X6.0-FCF	34.5	37.2	79.4	53	0.59	OR47.37X1.78X
2	50x8.0	HPF632-50X8.0-FCF	IP632-50X8.0-FCF	30.5	33.4	79.4	53	0.63	OR44.17X1.78X
2	60x6.0	HPF632-60X6.0-FCF	IP632-60X6.0-FCF	44.3	47.3	79.4	44	0.42	OR56.87X1.78X
2	60x8.0	HPF632-60X8.0-FCF	IP632-60X8.0-FCF	40.5	43.5	79.4	47	0.49	OR53.7X1.78X
2	65x8.0	HPF632-65X8.0-FCF	IP632-65X8.0-FCF	45.5	48.0	79.4	44	0.42	OR56.87X1.78X
2	66x8.5	HPF632-66X8.5-FCF	IP632-66X8.5-FCF	45.5	48.2	79.4	44	0.42	OR56.87X1.78X
2 1/2	75x12.5	HPF640-75X12.5-FCF	IP640-75X12.5-FCF	46.1	49.1	107.7	62	1.33	OR56.87X1.78X
2 1/2	80x10.0	HPF640-80X10.0-FCF	IP640-80X10.0-FCF	56.4	59.4	107.7	55	1.06	OR69.57X1.78X
3	97x12.0	HPF648-97X12.0-FCF	IP648-97X12.0-FCF	69.4	72.4	131.7	65	1.95	OR82.28X1.78X

Order code		
Part and Material	Suffix surface and material	Example
Insert: Steel, zinc plated, Cr(VI)-free O-Ring: NBR	FCF	IP612-25X3.0-FCF



HPF-FB90 – 90° Flange bend

ISO 6162-2 footprint

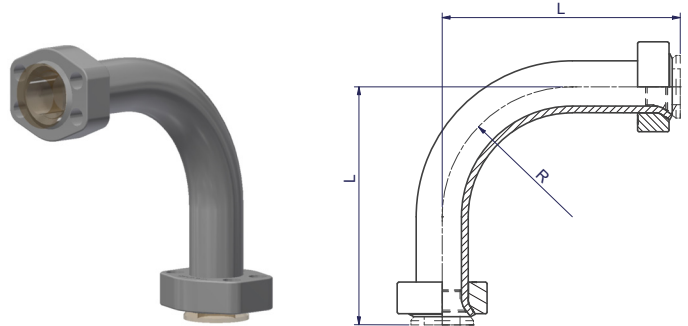

Size Inch	Tube	Complete Part Order code (Flanges and flared tube bend)	L	R
3/4	25x4.0	HPF612-25X4.0FB90CF*	140	63
1	38x6.0	HPF616-38X6.0FB90CF*	190	95
1 1/4	42x5.0	HPF620-42X5.0FB90CF*	200	105
1 1/2	50x8.0	HPF624-50X8.0FB90CF*	240	125
2	66x8.5	HPF632-66X8.5FB90CF*	310	165
2 1/2	80x10.0	HPF640-80X10.0FB90S	380	200
3	97x12.0	HPF648-97X12.0FB90S	450	243

Inserts not included

Other sizes on request

*All parts (tube and flange) in zinc plated steel, Cr(VI)-free

FB45 – 45° Flange bend

ISO 6162-2 footprint

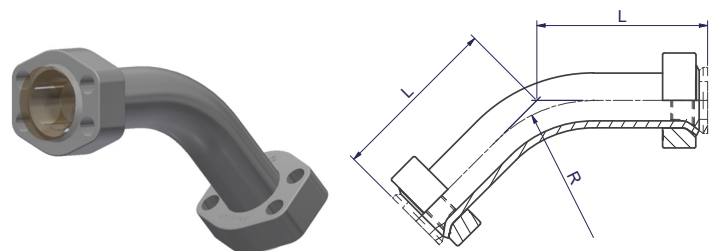

Size Inch	Tube	Complete Part Order code (Flanges and flared tube bend)	L	R
3/4	25x4.0	HPF612-25X4.0FB45CF*	110	63
1	38x6.0	HPF616-38X6.0FB45CF*	130	95
1 1/4	42x5.0	HPF620-42X5.0FB45CF*	140	105
1 1/2	50x8.0	HPF624-50X8.0FB45CF*	170	125
2	66x8.5	HPF632-66X8.5FB45CF*	210	165
2 1/2	80x10.0	HPF640-80X10.0FB45S	260	200
3	97x12.0	HPF648-97X12.0FB45S	310	243

Inserts not included

Other sizes on request

*All parts (tube and flange) in zinc plated steel, Cr(VI)-free

Order code		
Part and Material	Suffix surface and material	Example
Phosphated steel tube with zinc plated steel flange, Cr(VI)-free	S	HPF612-25X4.0FB90S

ENGINEERING YOUR SUCCESS.

LB - Flange L-block

ISO 6162-2 footprint

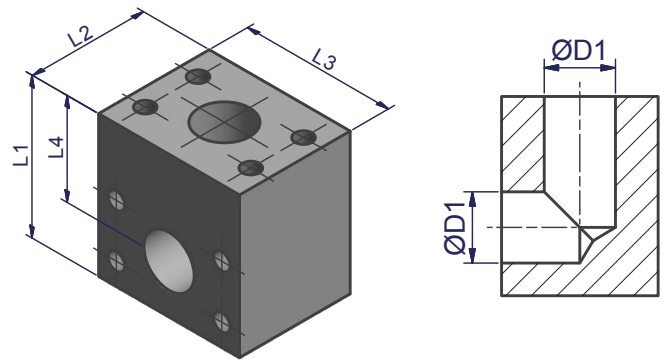

Size Inch	Order code	D1	L1	L2	L3	L4	Weight (Steel) kg/1 piece
3/4	LB612CFX	19.0	75.0	60.0	75.0	49.0	2.5
1	LB616CFX	25.0	80.0	65.0	80.0	54.0	2.8
1 1/4	LB620CFX	30.0	86.0	64.0	90.0	57.0	3.2
1 1/2	LB624CFX	38.0	100.0	74.0	100.0	66.0	4.6
2	LB632CFX	48.0	122.0	88.0	132.0	78.0	8.7
2 1/2	LB640CFX	60.0	175.0	152.0	178.0	99.0	32.4
3	LB648CFX	73.0	203.0	140.0	213.0	133.0	38.6

Other sizes on request

LBR - Flange L-block reducer

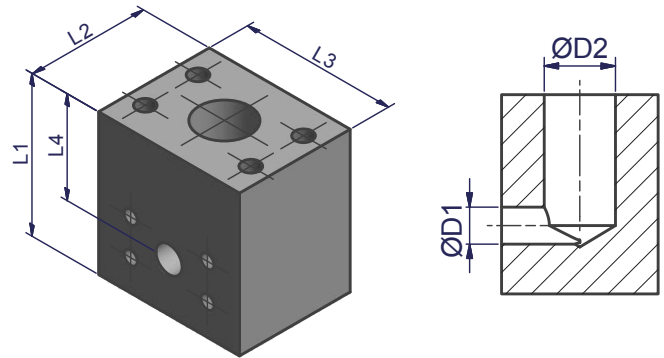

Size Inch	Order code	D1	D2	L1	L2	L3	L4	Weight (Steel) kg/1 piece	
1 - 3/4	LBR616-612CFX	19.0	25.0	80.0	65.0	80.0	54.0	2.9	
1 1/4 - 3/4	LBR620-612CFX	19.0	30.0	86.0	64.0	90.0	57.0	3.3	
1 1/4 - 1	LBR620-616CFX	25.0	30.0	86.0	64.0	90.0	57.0	3.3	
1 1/2 - 1	LBR624-616CFX	25.0	38.0	100.0	74.0	100.0	66.0	5.0	
1 1/2 - 1 1/4	LBR624-620CFX	30.0	38.0	100.0	74.0	100.0	66.0	4.8	
2 - 1 1/4	LBR632-620CFX	30.0	48.0	122.0	88.0	132.0	78.0	9.8	
2 - 1 1/2	LBR632-624CFX	38.0	48.0	122.0	88.0	132.0	78.0	9.1	
2 1/2 - 1 1/2	LBR640-624CFX	38.0	60.0	175.0	152.0	178.0	99.0	33.5	
2 1/2 - 2	LBR640-632CFX	48.0	60.0	175.0	152.0	178.0	99.0	33.0	
3 - 2	LBR648-632CFX	on request							
3 - 2 1/2	LBR648-640CFX	on request							

Other sizes on request



Order code			
Material	Suffix surface and material	Example Flange L-block	Example Flange L-block reducer
Steel, zinc plated, Cr(VI)-free	CFX	LB624CFX	LBR624-620CFX
Steel, oiled	SX	LB624SX	LBR624-620SX

TB - Flange T-block

ISO 6162-2 footprint

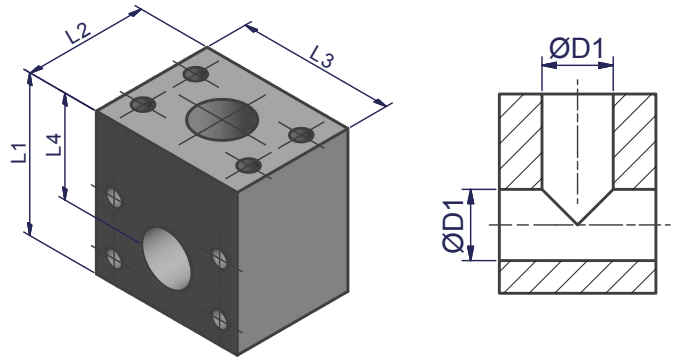

Size Inch	Order code	D1	L1	L2	L3	L4	Weight (Steel) kg/1 piece
3/4	TB612CFX	19.0	75.0	60.0	75.0	49.0	2.3
1	TB616CFX	25.0	80.0	65.0	80.0	54.0	2.5
1 1/4	TB620CFX	30.0	86.0	64.0	90.0	57.0	3.0
1 1/2	TB624CFX	38.0	100.0	74.0	100.0	66.0	4.6
2	TB632CFX	48.0	122.0	88.0	132.0	78.0	8.1
2 1/2	TB640CFX	60.0	155.0	120.0	175.0	100.0	19.5
3	TB648CFX	73.0	203.0	140.0	213.0	133.0	35.9

Other sizes on request

TBR - Flange T-block reducer

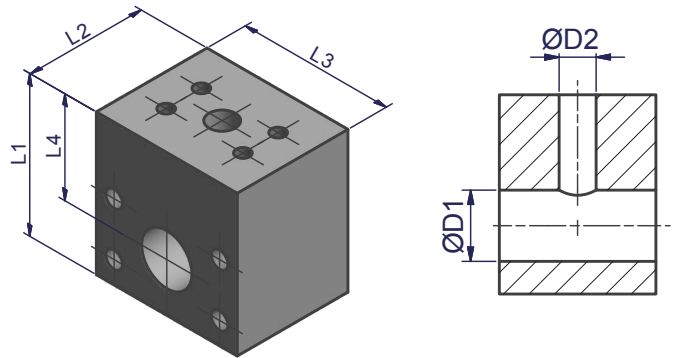

Size Inch	Order code	D1	D2	L1	L2	L3	L4	Weight (Steel) kg/1 piece
1 - 3/4 - 1	TBR616-612-616CFX	25.0	19.0	80.0	65.0	80.0	54.0	2.7
1 1/4 - 3/4 - 1 1/4	TBR620-612-620CFX	30.0	19.0	85.0	62.0	100.0	53.0	3.4
1 1/4 - 1 - 1 1/4	TBR620-616-620CFX	30.0	25.0	86.0	64.0	90.0	57.0	3.3
1 1/2 - 1 - 1 1/2	TBR624-616-624CFX	38.0	25.0	100.0	74.0	100.0	66.0	5.0
1 1/2 - 1 1/4 - 1 1/2	TBR624-620-624CFX	38.0	30.0	100.0	74.0	100.0	66.0	4.8
2 - 1 1/4 - 2	TBR632-620-632CFX	48.0	30.0	122.0	88.0	132.0	78.0	8.7
2 - 1 1/2 - 2	TBR632-624-632CFX	48.0	38.0	122.0	88.0	132.0	78.0	8.4
2 1/2 - 1 1/2 - 2 1/2	TBR640-624-640CFX	60.0	39.0	155.0	86.0	175.0	100.0	14.6
2 1/2 - 2 - 2 1/2	TBR640-632-640CFX	60.0	48.0	155.0	120.0	175.0	100.0	20.2
3 - 2 - 3	TBR648-632-648CFX	73.0	48.0	203.0	140.0	213.0	133.0	38.8
3 - 2 1/2 - 3	TBR648-640-648CFX							on request

Other sizes on request

Order code			
Material	Suffix surface and material	Example Flange T-block	Example Flange T-block reducer
Steel, zinc plated, Cr(VI)-free	CFX	TB624CFX	TBR624-620-624CFX
Steel, oiled	SX	TB624SX	TBR624-620-624SX

ENGINEERING YOUR SUCCESS.

Bolts and nuts

HPF ISO 6162-2 footprint



Size Inch	Tube	Connection Tube to Tube				Connection Tube to Port	
		Flange with through-hole – Flange with through-hole					
		Bolts ISO 4762 10.9 (DIN 912)		Nuts ISO 4032 10		Bolts ISO 4762 10.9 (DIN 912)	
		Description	Order code	Description	Order code	Description	Order code
3/4	25x3.0	M10x90	ZYLS10X90109ZNFLX	M10	ISO4032-M10-10ZNFLX	M10x50	ZYLS10X50109ZNFLX
3/4	25x4.0	M10x90	ZYLS12X90109ZNFLX	M10	ISO4032-M10-10ZNFLX	M10x50	ZYLS10X50109ZNFLX
1	30x4.0	M12x100	ZYLS12X100109ZNFLX	M12	ISO4032-M12-10ZNFLX	M12x55	ZYLS12X55109ZNFLX
1	30x5.0	M12x100	ZYLS12X100109ZNFLX	M12	ISO4032-M12-10ZNFLX	M12x60	ZYLS12X60109ZNFLX
1	38x4.0	M12x90	ZYLS12X90109ZNFLX	M12	ISO4032-M12-10ZNFLX	M12x55	ZYLS12X55109ZNFLX
1	38x6.0	M12x100	ZYLS12X100109ZNFLX	M12	ISO4032-M12-10ZNFLX	M12x55	ZYLS12X55109ZNFLX
1 1/4	38x4.0	M14x120	ZYLS14X120109ZNFLX	M14	ISO4032-M14-10ZNFLX	M14x65	ZYLS14X65109ZNFLX
1 1/4	38x4.0	M12x120	ZYLS12X120109ZNFLX	M12	ISO4032-M12-10ZNFLX	M12x60	ZYLS12X60109ZNFLX
1 1/4	38x5.0	M14x120	ZYLS14X120109ZNFLX	M14	ISO4032-M14-10ZNFLX	M14x65	ZYLS14X65109ZNFLX
1 1/4	38x5.0	M12x120	ZYLS12X120109ZNFLX	M12	ISO4032-M12-10ZNFLX	M12x60	ZYLS12X60109ZNFLX
1 1/4	38x6.0	M14x120	ZYLS14X120109ZNFLX	M14	ISO4032-M14-10ZNFLX	M14x70	ZYLS14X70109ZNFLX
1 1/4	38x6.0	M12x120	ZYLS12X120109ZNFLX	M12	ISO4032-M12-10ZNFLX	M12x65	ZYLS12X65109ZNFLX
1 1/4	42x5.0	M14x110	ZYLS14X110109ZNFLX	M14	ISO4032-M14-10ZNFLX	M14x65	ZYLS14X65109ZNFLX
1 1/4	42x5.0	M12x110	ZYLS12X110109ZNFLX	M12	ISO4032-M12-10ZNFLX	M12x60	ZYLS12X60109ZNFLX
1 1/2	38x5.0	M16x140	ZYLS16X140109ZNFLX	M16	ISO4032-M16-10ZNFLX	M16x80	ZYLS16X80109ZNFLX
1 1/2	50x3.0	M16x120	ZYLS16X120109ZNFLX	M16	ISO4032-M16-10ZNFLX	M16x70	ZYLS16X70109ZNFLX
1 1/2	50x5.0	M16x120	ZYLS16X120109ZNFLX	M16	ISO4032-M16-10ZNFLX	M16x70	ZYLS16X70109ZNFLX
1 1/2	50x6.0	M16x120	ZYLS16X120109ZNFLX	M16	ISO4032-M16-10ZNFLX	M16x70	ZYLS16X70109ZNFLX
1 1/2	50x8.0	M16x130	ZYLS16X130109ZNFLX	M16	ISO4032-M16-10ZNFLX	M16x70	ZYLS16X70109ZNFLX
2	50x5.0	M20x160	ZYLS20X160109ZNFLX	M20	ISO4032-M20-10ZNFLX	M20x90	ZYLS20X90109ZNFLX
2	50x6.0	M20x160	ZYLS20X160109ZNFLX	M20	ISO4032-M20-10ZNFLX	M20x90	ZYLS20X90109ZNFLX
2	50x8.0	M20x160	ZYLS20X160109ZNFLX	M20	ISO4032-M20-10ZNFLX	M20x90	ZYLS20X90109ZNFLX
2	60x6.0	M20x150	ZYLS20X150109ZNFLX	M20	ISO4032-M20-10ZNFLX	M20x90	ZYLS20X90109ZNFLX
2	60x8.0	M20x150	ZYLS20X150109ZNFLX	M20	ISO4032-M20-10ZNFLX	M20x90	ZYLS20X90109ZNFLX
2	65x8.0	M20x150	ZYLS20X150109ZNFLX	M20	ISO4032-M20-10ZNFLX	M20x85	ZYLS20X85109ZNFLX
2	66x8.5	M20x150	ZYLS20X150109ZNFLX	M20	ISO4032-M20-10ZNFLX	M20x85	ZYLS20X85109ZNFLX
2 1/2	75x12.5	M24x210	ZYLS24X210109ZNFLX	M24	ISO4032-M24-10ZNFLX	M24x120	ZYLS24X120109ZNFLX
2 1/2	80x10.0	M24x200	ZYLS24X200109ZNFLX	M24	ISO4032-M24-10ZNFLX	M24x120	ZYLS24X120109ZNFLX
3	97x12.0	M30x210	ZYLS30X210109ZNFLX	M30	ISO4032-M30-10ZNFLX	M30x130	ZYLS30X130109ZNFLX

Order code		
Part and Material	Suffix surface and material	Example
Bolt: Steel, grade 10.9, zinc flaked	ZNFLX	ZYLS10X80109ZNFLX
Nut: Steel, grade 10.9, zinc flaked	ZNFLX	ISO4032-M10-10ZNFLX



KH – Ball valve drilled and tapped for SAE 6000 and SAE 3000 flanges

SAE 6000/ISO 6162-2

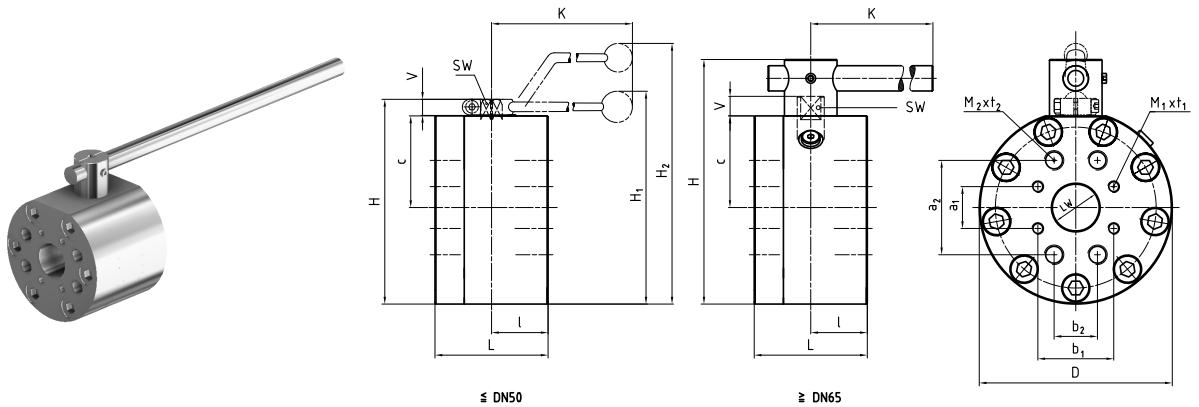

Material Steel

Size Inch	Order Code	DN	LW	L	I	D	H	c	V	K	SW	SAE 3000 boring pattern				SAE 6000 boring pattern				H1	H2	Material Code	Lever	Weight kg	W.P. bar
												a1	b1	M1	t1	a2	b2	M2	t2						
3/4	KH12-20CF	20	20	80	35	98	100	36.5	14	170	14	22.2	47.6	M10	18	50.8	23.8	M10	18	-	150	212A	St	4.20	350 / 420
1	KH16-25CF	25	25	88	38	118	113	39.5	14	170	14	26.2	52.4	M10	20	57.2	27.8	M12	20	-	163	212A	St	6.00	320 / 420
1 1/4	KH20-32CF*	32	32	100	50	145	158	68.0	17	306	17	30.2	58.7	M10	20	66.7	31.8	M12	22	-	232	212A	St	11.70	280 / 420
1 1/4	KH20-32TM1214CF*	32	32	100	50	145	158	68.0	17	306	17	30.2	58.7	M12	20	66.7	31.8	M14	22	-	232	212A	St	11.65	210 / 400
1 1/2	KH24-38CF	40	38	110	55	165	178	78.0	17	306	17	35.7	69.9	M12	20	79.4	36.5	M16	27	-	252	212A	St	17.10	210 / 420
2	KH32-48CF	50	48	116	58	198	210	94.0	17	306	17	42.9	77.8	M12	20	96.8	44.5	M20	28	-	284	212A	St	24.60	210 / 420
2 1/2	KH40-63CF	65	63	170	75	218	275	100.0	20	600	16	88.9	50.8	M12	19	58.7	123.8	M24	41	-	-	282A	St	44.40	175 / 420
3	KH48-76CF	80	76	170	79	258	315	115.0	26	600	19	106.4	61.9	M16	24	71.4	152.4	M30	47	-	-	282A	St	54.90	160 / 420

*Please choose between KH20-32CF and KH20-32TM1214CF according to needed connection threads M1 and M2.
Steel ball valves 1/2" up to 2" with SAE 3000 and SAE 6000 boring pattern.
The bore pattern for 2 1/2" and 3" is turned to 90°.

Order code			
Material	Suffix surface and material	Example	Comments
Steel, zinc plated, Cr(VI)-free	CF	KH20-32CF	

	Material 221A	Material 282A
Body	Stahl	Steel
Ball	Stahl	Steel
Stem	Stahl	Stainless Steel
Ball seats	POM	POM
O-Ring	NBR	NBR
Tmin / Tmax	-10°C / 100°C	-10°C / 100°C



HPF – ISO 6164 flange

ENGINEERING YOUR SUCCESS.

HPF – ISO 6164 flange

HPF – Square flange design

ISO 6164 footprint

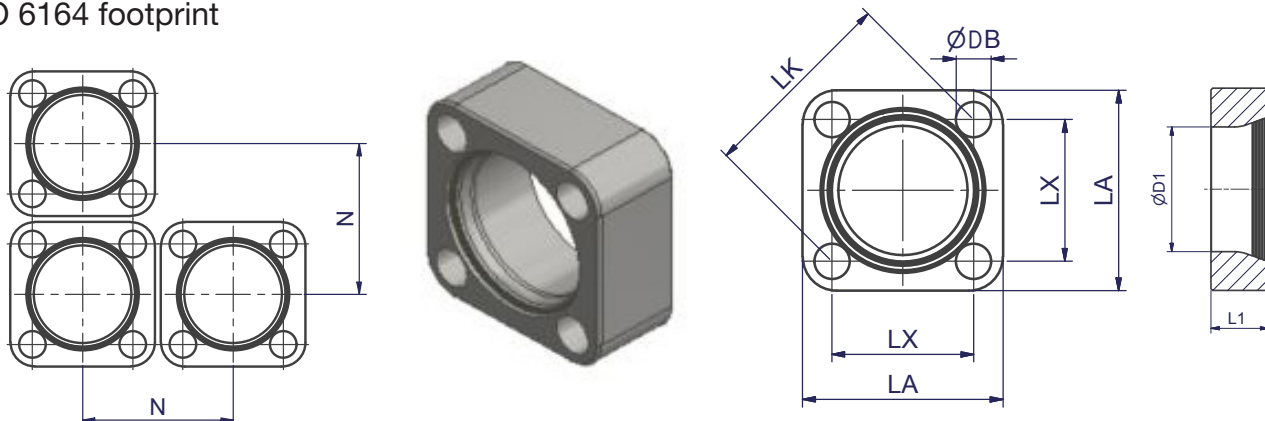

Size Inch	Tube O.D.	Order code	LK	D1	L1	LA	LX	DB	N	Weight (Steel) kg/1 piece	PN (bar)
2	50.0	HPF432-50CFX	98	50.5	40	100	69.3	17.5	105	2.1	420
2	60.0	HPF432-60CFX	98	61.0	40	100	69.3	17.5	105	1.7	420
2 1/2	60.0	HPF440-60CFX	118	61.0	50	120	83.4	22.0	125	3.8	420
2 1/2	75.0	HPF440-75CFX	118	76.0	52	120	83.4	22.0	125	3.2	420
2 1/2	80.0	HPF440-80CFX	118	81.0	52	120	83.4	22.0	125	2.8	420
3	80.0	HPF448-80CFX	145	81.0	52	150	102.5	26.0	155	6.0	420
3	88.0	HPF448-88CFX	145	89.0	52	150	102.5	26.0	155	5.8	420
3	90.0	HPF448-90CFX	145	91.0	52	150	102.5	26.0	155	5.7	420
3	97.0	HPF448-97CFX	145	98.0	52	150	102.5	26.0	155	4.9	420
3	101.6	HPF448-101.6CFX	145	102.7	52	150	102.5	26.0	155	4.7	420
3 1/2	101.6	HPF456-101.6CFX	160	102.5	60	160	113.1	26.0	165	6.8	420
4	115.0	HPF464-115CFX	175	116.0	70	180	123.7	33.0	185	9.4	420

HPF - Round flange design

Footprint deviating from ISO 6164

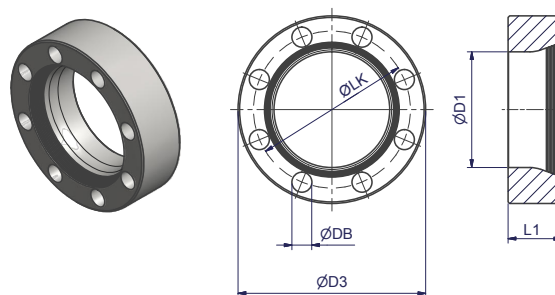

Size Inch	Tube OD	Order code	LK	D1	L1	D3	DB	Weight (Steel) kg/1 piece	PN (bar)
4 1/2	130	HPF872-130CFX	175	131.1	60	214	22	8.6	420
5	150	HPF880-150CFX	205	151.1	70	245	26	12.9	420

Order code		
Part and Material	Suffix surface and material	Example
Flange: Steel, zinc plated, Cr(VI)-free	CFX	HPF432-50CFX

Pressure ratings (PN) refer to the flanges. Effective pressure depends on the used tube and operating temperature (page 14-16).



IPV – Insert with F37-Profile seal

ISO 6164 footprint

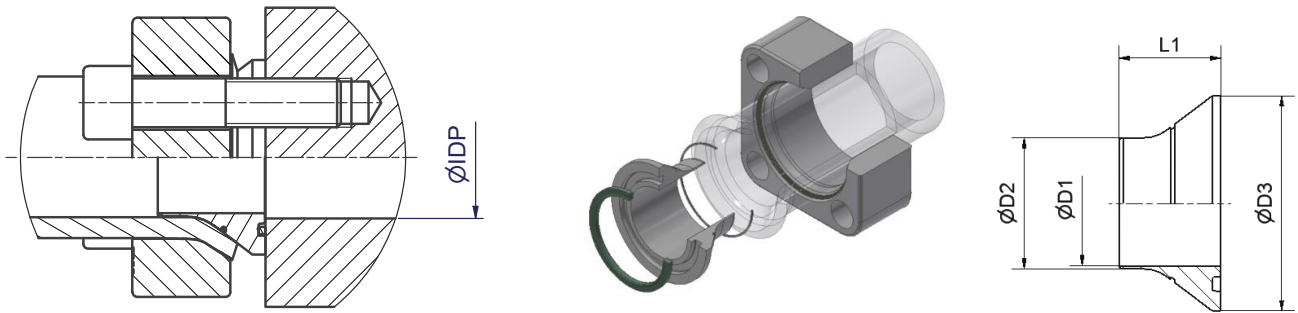

Size Inch	Tube	Complete part (flange incl. insert and seal)	Insert (incl. seals)	D1	D2	D3	L1	IDP (inner-Ø of the port)	Weight (Steel) kg/1 piece	F37 seal (face seal)***	Alternative O-Ring (face-seal)***	O-Ring (tube seal)
2	50x8.0	HPF432-50X8.0-VCF	IP432-50X8.0-VCF	29.9	32.9	79.4	53.3	48	0.57	F37S432X	OR56.52X5.33X	OR44.17X1.78X
2	60x8.0	HPF432-60X8.0-VCF	IP432-60X8.0-VCF	40.0	43.0	79.4	47.3	48	0.47	F37S432X	OR56.52X5.33X	OR53.7X1.78X
2 1/2	60x8.0	HPF440-60X8.0-VCF	IP440-60X8.0-VCF	40.0	43.0	94.2	57.0	54	0.88	F37S440X	OR69.22X5.33X	OR53.7X1.78X
2 1/2	75x12.5	HPF440-75X12.5-VCF	IP440-75X12.5-VCF	46.5	49.5	94.2	53.0	54	0.72	F37S440X	OR69.22X5.33X	OR56.87X1.78X
2 1/2	80x10.0	HPF440-80X10.0-VCF	IP440-80X10.0-VCF	56.4	59.4	94.2	46.0	54	0.56	F37S440X	OR69.22X5.33X	OR69.57X1.78X
3	80x8.0	HPF448-80X8.0-VCF	IP448-80X8.0-VCF	60.5	63.5	104.0	49.0	58	0.75	F37S448X	OR75.57X5.33X	OR72.75X1.78X
3	80x10.0	HPF448-80X10.0-VCF	IP448-80X10.0-VCF	56.5	59.4	104.0	52.0	58	0.86	F37S448X	OR75.57X5.33X	OR69.57X1.78X
3	88x14.0	HPF448-88X14.0-VCF	IP448-88X14.0-VCF	56.5	59.4	104.0	52.0	58	0.86	F37S448X	OR75.57X5.33X	OR72.75X1.78X
3	90x9.0	HPF448-90X9.0-VCF	IP448-90X9.0-VCF	58.0	71.4	104.0	45.0	58	0.79	F37S448X	OR75.57X5.33X	OR82.27X1.78X
3	97x12.0	HPF448-97X12.0-VCF	IP448-97X12.0-VCF	59.0	72.4	104.0	46.0	58	0.81	F37S448X	OR75.57X5.33X	OR82.27X1.78X
3	97x12.0	HPFRR448-97X12.0-VCF**	IPRR448-97X12.0-VCF**	59.0	72.4	104.0	46.0	73**	0.82	F37RS48X	OR78.97X3.53X	OR82.27X1.78X
3	101.6x16.0	HPF448-101.6X16.0-VCF	IP448-101.6X16.0-VCF	58.0	69.0	104.0	48.0	58	0.88	F37S448X	OR75.57X5.33X	OR82.27X1.78X
3 1/2	101.6x16.0	HPF456-101.6X16.0-VCF	IP456-101.6X16.0-VCF	66.0	69.0	119.0	58.0	66	1.30	F37S456X	OR85.09X5.33X	OR82.27X1.78X
4	115x15.0	HPF464-115X15.0-VCF	IP464-115X15.0-VCF	76.0	84.4	128.0	54.0	74	1.40	F37S464X	OR88.27X5.33X	OR101.32X1.78X
4	115x15.0	HPFRR464-115X15.0-VCF**	IPRR464-115X15.0-VCF**	76.0	84.4	128.0	54.0	85**	1.42	F37RS64X	OR94.84X3.53X	OR101.32X1.78X
4 1/2	130x15.0	HPF872-130X15.0-VCF*	IP872-130X15.0-VCF	95.4	99.4	140.0	56.0	95	1.54	F37S872X	OR110.49X5.33X	OR113.97X2.62X
5	150x15.0	HPF880-150X15.0-VCF*	IP880-150X15.0-VCF	115.4	119.4	166.0	60.0	115	2.23	F37S880X	OR129.54X5.33X	OR139.37X2.62X

*Round flange design, footprint deviating from ISO 6164, see page 56.

**IPRR are adapter inserts for bigger IDP than metric standard.

***Face seals are designed for the corresponding IDP. Inserts for bigger IDP on request.

Insert IP...ORCF with NBR O-Ring seal alternative to F37 seal.

Order code		
Part and Material	Suffix surface and material	Example
Insert: Steel, zinc plated, Cr(VI)-free F37 seal: PUR O-Ring: NBR	VCF	IP432-50X8.0-VCF
Insert: Steel, zinc plated, Cr(VI)-free O-Ring: NBR	ORCF	IP432-50X8.0-ORCF

HPF – ISO 6164 flange

IPF – Insert with flat face

ISO 6164 footprint

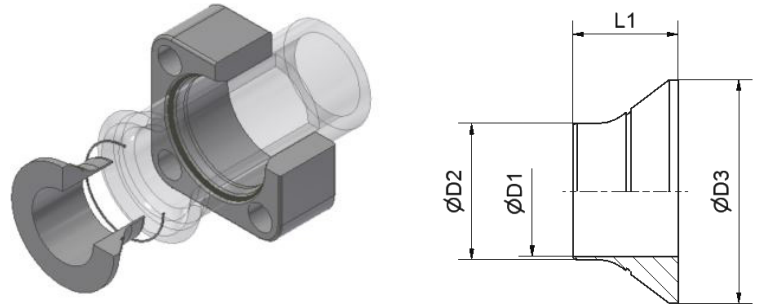

Size Inch	Tube	Complete part (flange incl. insert and seal)	Insert (incl. seals)	D1	D2	D3	L1	Weight (Steel) kg/1 piece	O-Ring
2	50x8.0	HPF432-50X8.0-FCF	IP432-50X8.0-FCF	29.9	32.9	79.4	53.3	0.57	OR44.17X1.78X
2	60x8.0	HPF432-60X8.0-FCF	IP432-60X8.0-FCF	40.0	43.0	79.4	47.3	0.47	OR53.7X1.78X
2 1/2	60x8.0	HPF440-60X8.0-FCF	IP440-60X8.0-FCF	40.0	43.0	94.2	57.0	0.88	OR53.7X1.78X
2 1/2	75x12.5	HPF440-75X12.5-FCF	IP440-75X12.5-FCF	46.5	49.5	94.2	53.0	0.72	OR56.87X1.78X
2 1/2	80x10.0	HPF440-80X10.0-FCF	IP440-80X10.0-FCF	56.4	59.4	94.2	46.0	0.56	OR69.57X1.78X
3	80x8.0	HPF448-80X8.0-FCF	IP448-80X8.0-FCF	60.5	63.5	104.0	49.0	0.75	OR72.75X1.78X
3	80x10.0	HPF448-80X10.0-FCF	IP448-80X10.0-FCF	56.5	59.4	104.0	52.0	0.86	OR69.57X1.78X
3	88x14.0	HPF448-88X14.0-FCF	IP448-88X14.0-FCF	56.5	59.4	104.0	52.0	0.86	OR72.75X1.78X
3	90x9.0	HPF448-90X9.0-FCF	IP448-90X9.0-FCF	58.0	71.4	104.0	45.0	0.79	OR82.27X1.78X
3	97x12.0	HPF448-97X12.0-FCF	IP448-97X12.0-FCF	59.0	72.4	104.0	46.0	0.81	OR82.27X1.78X
3	101.6x16.0	HPF448-101.6X16.0-FCF	IP448-101.6X16.0-FCF	58.0	69.0	104.0	48.0	0.88	OR82.27X1.78X
3 1/2	101.6x16.0	HPF456-101.6X16.0-FCF	IP456-101.6X16.0-FCF	66.0	69.0	119.0	58.0	1.36	OR82.27X1.78X
4	115x15.0	HPF464-115X15.0-FCF	IP464-115X15.0-FCF	76.0	84.4	128.0	54.0	1.46	OR101.32X1.78X
4 1/2	130x15.0	HPF872-130X15.0-FCF*	IP872-130X15.0-FCF	95.4	99.4	140.0	56.0	1.61	OR113.97X2.62X
5	150x15.0	HPF880-150X15.0-FCF*	IP880-150X15.0-FCF	115.4	119.4	166.0	60.0	2.32	OR139.37X2.62X

*Round flange design, footprint deviating from ISO 6164, see page 56.

Order code		
Part and Material	Suffix surface and material	Example
Insert: Steel, zinc plated, Cr(VI)-free O-Ring: NBR	FCF	IP432-50X8.0-FCF



HPF-FB90 – 90° Flange bend

ISO 6164 footprint

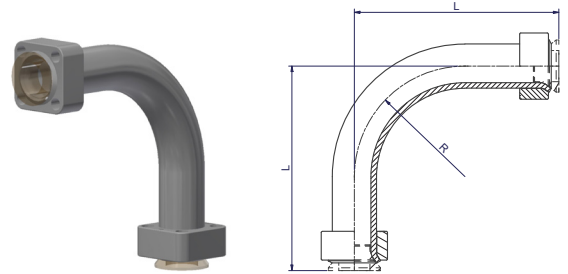

Size Inch	Tube	Complete Part Order code (Flanges and flared tube bend)	L	R
2	60x8.0	HPF432-60X8.0FB90CF**	290	150
2 1/2	80x10.0	HPF440-80X10.0FB90S	380	200
3	97x12.0	HPF448-97X12.0FB90S	450	243
3 1/2	101.6x16.0	HPF456-101.6X16.0FB90S	570	305
4	115x15.0	HPF464-115X15.0FB90S	540	288
4 1/2	130x15.0	HPF872-130X15.0FB90S*	620	325
5	150x15.0	HPF880-150X15.0FB90S*	710	450

Inserts not included

Other sizes on request

*Round flange design, footprint deviating from ISO 6164 (see page 56)

**All parts (tube and flange) in zinc plated steel, Cr(VI)-free

HPF-FB45 – 45° Flange bend

ISO 6164 footprint

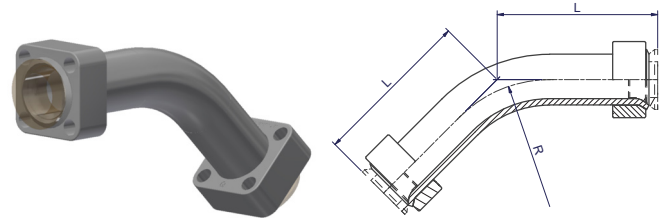

Size Inch	Tube	Complete Part Order code (Flanges and flared tube bend)	L	R
2	60x8.0	HPF432-60X8.0FB45CF**	200	150
2 1/2	80x10.0	HPF440-80X10.0FB45S	260	200
3	97x12.0	HPF448-97X12.0FB45S	310	243
3 1/2	101.6x16.0	HPF456-101.6X16.0FB45S	400	305
4	115x15.0	HPF464-115X15.0FB45S	360	288
4 1/2	130x15.0	HPF872-130X15.0FB45S*	420	325
5	150x15.0	HPF880-150X15.0FB45S*	450	450

Inserts not included

Other sizes on request

*Round flange design, footprint deviating from ISO 6164 (see page 56)

**All parts (tube and flange) in zinc plated steel, Cr(VI)-free

Order code		
Part and Material	Suffix surface and material	Example
Phosphated steel tube with zinc plated steel flange, Cr(VI)-free	S	HPF440-80X10.0FB90S

HPF – ISO 6164 flange

LB(HPF) - Flange L-block

ISO 6164 footprint

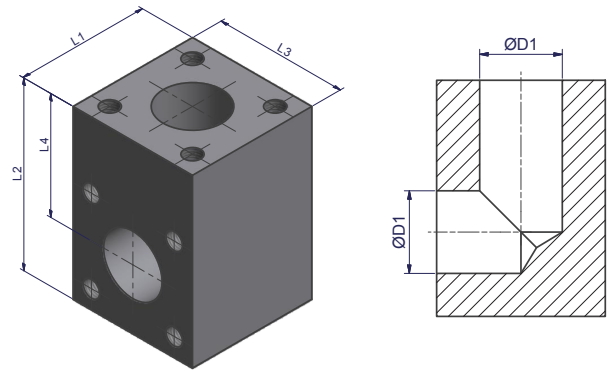

Size Inch	Order code	D1	L1	L2	L3	L4	Weight (Steel) kg/1 piece	
2	LB432CFX	48.0	100.0	140.0	100.0	90.0	8.7	
2 1/2	LBHPF440CFX	54.0	120.0	160.0	120.0	100.0	14.2	
3	LBHPF448CFX	58.0	150.0	200.0	150.0	125.0	29.3	
3 1/2	LBHPF456CFX	66.0	160.0	205.0	160.0	125.0	33.7	
4	LBHPF464CFX	74.0	180.0	240.0	180.0	150.0	49.2	
4 1/2	LBHPF872CFX	on request						
5	LBHPF880CFX	on request						

Other sizes on request

LBR(HPF) - Flange L-block reducer

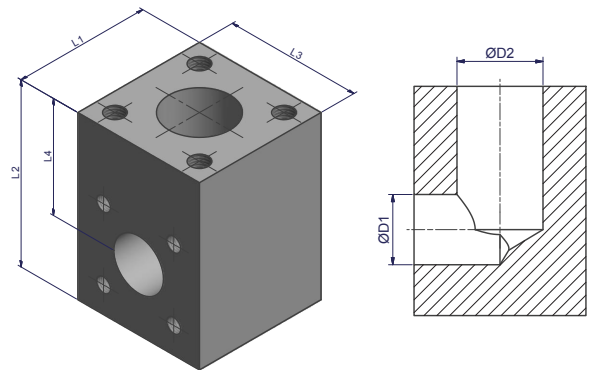

Size Inch	Order code	D1	D2	L1	L2	L3	L4	Weight (Steel) kg/1 piece
2 1/2 - 2	LBRHPF440-432CFX	48.0	54.0	120.0	160.0	120.0	100.0	15.0
3 - 2	LBRHPF448-432CFX	48.0	58.0	150.0	200.0	150.0	125.0	31.0
3 - 2 1/2	LBRHPF448-440CFX	54.0	58.0	150.0	200.0	150.0	125.0	29.9
3 1/2 - 2 1/2	LBRHPF456-440CFX	54.0	66.0	160.0	205.0	160.0	125.0	34.9
3 1/2 - 3	LBRHPF464-448CFX	58.0	66.0	160.0	205.0	160.0	125.0	34.2
4 - 3	LBRHPF464-448CFX	58.0	74.0	180.0	240.0	180.0	150.0	51.4
4 - 3 1/2	LBRHPF464-456CFX	66.0	74.0	180.0	240.0	180.0	150.0	51.0
4 1/2 - 3 1/2	LBRHPF872-456CFX	on request						
4 1/2 - 4	LBRHPF872-464CFX	on request						
5 - 4	LBRHPF880-464CFX	on request						
5 - 4 1/2	LBRHPF880-872CFX	on request						

Other sizes on request

Order code			
Material	Suffix surface and material	Example Flange L-block	Example Flange L-block reducer
Steel, zinc plated, Cr(VI)-free	CFX	LBHPF440CFX	LBRHPF440-432CFX
Steel, oiled	SX	LBHPF440SX	LBRHPF440-432SX



TB(HPF) - Flange T-block

ISO 6164 footprint

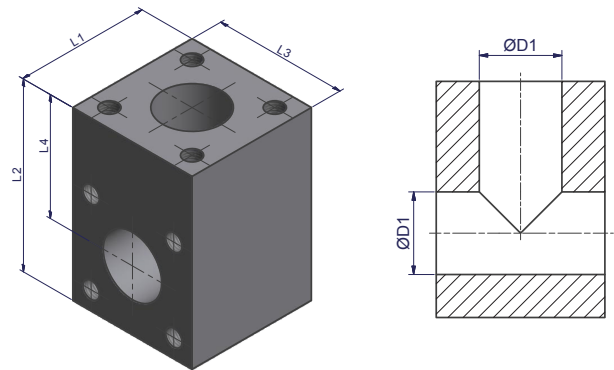

Size Inch	Order code	D1	L1	L2	L3	L4	Weight (Steel) kg/1 piece	
2	TB432CFX	48.0	100.0	140.0	100.0	90.0	8.0	
2 1/2	TBHPF440CFX	54.0	120.0	160.0	120.0	100.0	13.4	
3	TBHPF448CFX	58.0	150.0	200.0	150.0	125.0	28.1	
3 1/2	TBHPF456CFX	66.0	160.0	205.0	160.0	125.0	32.1	
4	TBHPF464CFX	74.0	180.0	240.0	180.0	150.0	46.9	
4 1/2	TBHPF872CFX	95.0	220.0	250.0	220.0	140.0	73.7	
5	TBHPF880CFX	on request						

Other sizes on request

TBR - Flange T-block reducer

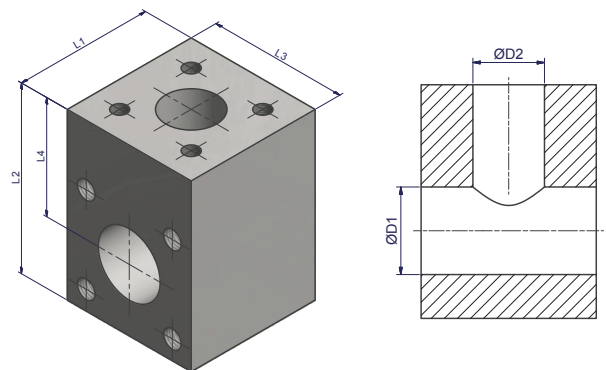

Size Inch	Order code	D1	D2	L1	L2	L3	L4	Weight (Steel) kg/1 piece
2 1/2 - 2 - 2 1/2	TBRHPF440-432-440CFX	54.0	48.0	120.0	160.0	120.0	100.0	14.0
3 - 2 - 3	TBRHPF448-432-448CFX	58.0	48.0	150.0	200.0	150.0	125.0	29.5
3 - 2 1/2 - 3	TBRHPF448-440-448CFX	58.0	54.0	150.0	200.0	150.0	125.0	28.5
3 1/2 - 2 1/2 - 3 1/2	TBRHPF456-440-456CFX	66.0	54.0	160.0	205.0	160.0	125.0	33.2
3 1/2 - 3 - 3 1/2	TBRHPF456-448-456CFX	66.0	58.0	160.0	205.0	160.0	125.0	32.7
4 - 3 - 4	TBRHPF464-448-464CFX	74.0	58.0	180.0	240.0	180.0	150.0	49.0
4 - 3 1/2 - 4	TBRHPF464-456-464CFX	74.0	66.0	180.0	240.0	180.0	150.0	48.3
4 1/2 - 3 1/2 - 4 1/2	TBRHPF872-456-872CFX	on request						
4 1/2 - 4 - 4 1/2	TBRHPF872-464-872CFX	on request						
5 - 4 - 5	TBRHPF880-464-880CFX	on request						
5 - 4 1/2 - 5	TBRHPF880-872-880CFX	on request						

Other sizes on request

Order code			
Material	Suffix surface and material	Example Flange T-block	Example Flange T-block reducer
Steel, zinc plated, Cr(VI)-free	CFX	TB440CFX	TBR440-432-440CFX
Steel, oiled	SX	TB440SX	TBR440-432-440SX

ENGINEERING YOUR SUCCESS.

HPF – ISO 6164 flange

Bolts and nuts

HPF ISO 6164 footprint



Size Inch	Tube	Connection Tube to Tube				Connection Tube to Port	
		Flange with through-hole – Flange with through-hole					
		Bolts ISO 4762 10.9 (DIN 912)		Nuts ISO 4032 10		Bolts ISO 4762 10.9 (DIN 912)	
		Description	Order code	Description	Order code	Description	Order code
2	50x8.0	M16x160	ZYLS16X160109ZNFLX	M16	ISO4032-M16-10ZNFLX	M16x90	ZYLS16X90109ZNFLX
2	60x8.0	M16x140	ZYLS16X140109ZNFLX	M16	ISO4032-M16-10ZNFLX	M16x80	ZYLS16X80109ZNFLX
2 1/2	60x8.0	M20x180	ZYLS20X180109ZNFLX	M20	ISO4032-M20-10ZNFLX	M20x100	ZYLS20X100109ZNFLX
2 1/2	75x12.5	M20x190	ZYLS20X190109ZNFLX	M20	ISO4032-M20-10ZNFLX	M20x110	ZYLS20X110109ZNFLX
2 1/2	80x10.0	M20x200	ZYLS20X200109ZNFLX	M20	ISO4032-M20-10ZNFLX	M20x100	ZYLS20X100109ZNFLX
3	80x8.0	M24x180	ZYLS24X180109ZNFLX	M24	ISO4032-M24-10ZNFLX	M24x110	ZYLS24X110109ZNFLX
3	80x10.0	M24x190	ZYLS24X190109ZNFLX	M24	ISO4032-M24-10ZNFLX	M24x110	ZYLS24X110109ZNFLX
3	88x14.0	M24x190	ZYLS24X190109ZNFLX	M24	ISO4032-M24-10ZNFLX	M24x110	ZYLS24X110109ZNFLX
3	90x9.0	M24x180	ZYLS24X180109ZNFLX	M24	ISO4032-M24-10ZNFLX	M24x100	ZYLS24X100109ZNFLX
3	97x12.0	M24x160	ZYLS24X160109ZNFLX	M24	ISO4032-M24-10ZNFLX	M24x100	ZYLS24X100109ZNFLX
3	101.6x16.0	M24x180	ZYLS24X180109ZNFLX	M24	ISO4032-M24-10ZNFLX	M24x100	ZYLS24X100109ZNFLX
3 1/2	101.6x16.0	M24x200	ZYLS24X200109ZNFLX	M24	ISO4032-M24-10ZNFLX	M24x120	ZYLS24X120109ZNFLX
4	115x15.0	M30x210	ZYLS30X210109ZNFLX	M30	ISO4032-M30-10ZNFLX	M30x120	ZYLS30X120109ZNFLX
4 1/2	130x15.0	M20x180	ZYLS20X180109ZNFLX	M20	ISO4032-M20-10ZNFLX	M20x100	ZYLS20X100109ZNFLX
5	150x15.0	M24x220	ZYLS24X220109ZNFLX	M24	ISO4032-M24-10ZNFLX	M24x130	ZYLS24X130109ZNFLX

Order code		
Part and Material	Suffix surface and material	Example
Bolt: Steel, grade 10.9, zinc flaked	ZNFLX	ZYLS16X120109ZNFLX
Nut: Steel, grade 10.9, zinc flaked	ZNFLX	ISO4032-M16-10ZNFLX



KH – Ball valve drilled and tapped for ISO 6164 flanges

ISO 6164

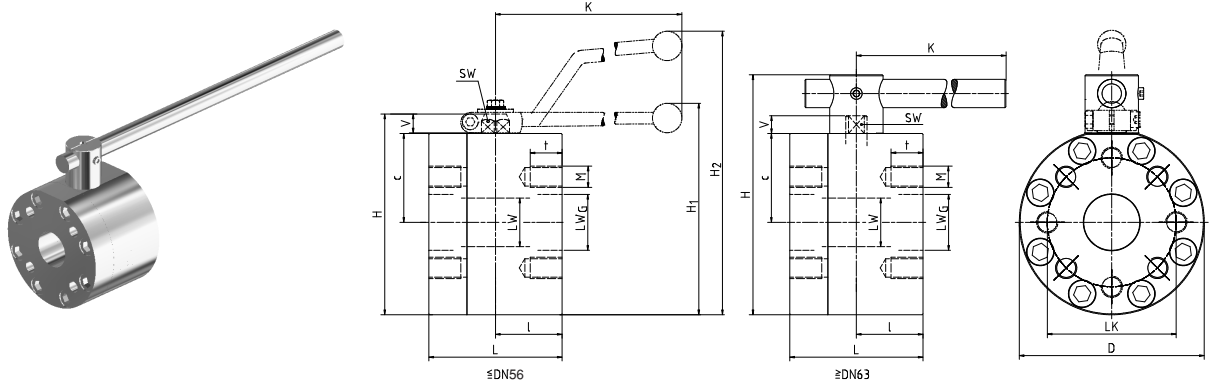

Material Steel

Size Inch	Order Code	DN	LW	LWG	L	I	D	H	c	V	K	SW	LK	M	t	H2	Material Code	Lever	Weight kg	W.P. bar
2	KH432-48CF	50	48	43	123	58	198	210	94	17	306	17	98	4x M16	25.5	283	212A	St	24.90	400
2 1/2	KH440-48CF	56	48	53	123	58	198	210	94	17	306	17	118	4x M20	31.0	283	212A	St	26.60	400
3	KH448-63CF	65	65	63	150	75	208	270	100	20	600	16	145	4x M24	36.0	-	282A	St	36.00	350
4	KH464-88CF	90	100	86	170	85	260	327	122	26	900	24	175	4x M30	31.0	-	282A	St	61.00	350
4 1/2	KH872-100CF	100	100	100	170	85	260	327	122	26	900	24	175	8x M20	33.0	-	282A	St	70.00	350
5	KH880-118CF	125	118	118	210	105	300	380	140	32	900	36	205	8x M24	34.0	-	282A	St	99.00	350

Other sizes on request.

Order code		
Material	Suffix surface and material	Example
Steel, zinc plated, Cr(VI)-free	CF	KH432-48CF

	Material		
	212A	282A	242A
Body	Steel	Steel	Steel
Ball	Steel	Steel	Stainless Steel
Stem	Steel	Stainless Steel	Stainless Steel
Ball seats	POM	POM	POM
O-Ring	NBR	NBR	NBR
Tmin / T max	-10°C / 100°C	-10°C / 100°C	-10°C / 100°C



Parker's Motion & Control Technologies

At Parker, we're guided by a relentless drive to help our customers become more productive and achieve higher levels of profitability by engineering the best systems for their requirements. It means looking at customer applications from many angles to find new ways to create value. Whatever the motion and control technology need, Parker has the experience, breadth of product and global reach to consistently deliver. No company knows more about motion and control technology than Parker. For further info call 00800 27 27 5374



Aerospace

Key Markets

- Aftermarket services
- Commercial transports
- Engines
- General & business aviation
- Helicopters
- Launch vehicles
- Military aircraft
- Missiles
- Power generation
- Regional transports
- Unmanned aerial vehicles

Key Products

- Control systems & actuation products
- Engine systems & components
- Fluid conveyance systems & components
- Fluid metering, delivery & atomization devices
- Fuel systems & components
- Fuel tank inerting systems
- Hydraulic systems & components
- Thermal management
- Wheels & brakes



Climate Control

Key Markets

- Agriculture
- Air conditioning
- Construction Machinery
- Food & beverage
- Industrial machinery
- Life sciences
- Oil & gas
- Precision cooling
- Process
- Refrigeration
- Transportation

Key Products

- Accumulators
- Advanced actuators
- CO₂ controls
- Electronic controllers
- Filter driers
- Hand shut-off valves
- Heat exchangers
- Hose & fittings
- Pressure regulating valves
- Refrigerant distributors
- Safety relief valves
- Smart pumps
- Solenoid valves
- Thermostatic expansion valves



Electromechanical

Key Markets

- Aerospace
- Factory automation
- Life science & medical
- Machine tools
- Packaging machinery
- Paper machinery
- Plastics machinery & converting
- Primary metals
- Semiconductor & electronics
- Textile
- Wire & cable

Key Products

- AC/DC drives & systems
- Electric actuators, gantry robots & slides
- Electrohydraulic actuation systems
- Electromechanical actuation systems
- Human machine interface
- Linear motors
- Stepper motors, servo motors, drives & controls
- Structural extrusions



Filtration

Key Markets

- Aerospace
- Food & beverage
- Industrial plant & equipment
- Life sciences
- Marine
- Mobile equipment
- Oil & gas
- Power generation & renewable energy
- Process
- Transportation
- Water Purification

Key Products

- Analytical gas generators
- Compressed air filters & dryers
- Engine air, coolant, fuel & oil filtration systems
- Fluid condition monitoring systems
- Hydraulic & lubrication filters
- Hydrogen, nitrogen & zero air generators
- Instrumentation filters
- Membrane & fiber filters
- Microfiltration
- Sterile air filtration
- Water desalination & purification filters & systems



Fluid & Gas Handling

Key Markets

- Aerial lift
- Agriculture
- Bulk chemical handling
- Construction machinery
- Food & beverage
- Fuel & gas delivery
- Industrial machinery
- Life sciences
- Marine
- Mining
- Mobile
- Oil & gas
- Renewable energy
- Transportation

Key Products

- Check valves
- Connectors for low pressure fluid conveyance
- Deep sea umbilicals
- Diagnostic equipment
- Hose couplings
- Industrial hose
- Mooring systems & power cables
- PTFE hose & tubing
- Quick couplings
- Rubber & thermoplastic hose
- Tube fittings & adapters
- Tubing & plastic fittings



Hydraulics

Key Markets

- Aerial lift
- Agriculture
- Alternative energy
- Construction machinery
- Forestry
- Industrial machinery
- Machine tools
- Marine
- Material handling
- Mining
- Oil & gas
- Power generation
- Refuse vehicles
- Renewable energy
- Truck hydraulics
- Turf equipment

Key Products

- Accumulators
- Cartridge valves
- Electrohydraulic actuators
- Human machine interfaces
- Hybrid drives
- Hydraulic cylinders
- Hydraulic motors & pumps
- Hydraulic systems
- Hydraulic valves & controls
- Hydrostatic steering
- Integrated hydraulic circuits
- Power take-offs
- Power units
- Rotary actuators
- Sensors



Pneumatics

Key Markets

- Aerospace
- Conveyor & material handling
- Factory automation
- Life science & medical
- Machine tools
- Packaging machinery
- Transportation & automotive

Key Products

- Air preparation
- Brass fittings & valves
- Manifolds
- Pneumatic accessories
- Pneumatic actuators & grippers
- Pneumatic valves & controls
- Quick disconnects
- Rotary actuators
- Rubber & thermoplastic hose & couplings
- Structural extrusions
- Thermoplastic tubing & fittings
- Vacuum generators, cups & sensors



Process Control

Key Markets

- Alternative fuels
- Biopharmaceuticals
- Chemical & refining
- Food & beverage
- Marine & shipbuilding
- Medical & dental
- Microelectronics
- Nuclear Power
- Offshore oil exploration
- Oil & gas
- Pharmaceuticals
- Power generation
- Pulp & paper
- Steel
- Water/wastewater

Key Products

- Analytical Instruments
- Analytical sample conditioning products & systems
- Chemical injection fittings & valves
- Fluoropolymer chemical delivery fittings, valves & pumps
- High purity gas delivery fittings, valves, regulators & digital flow controllers
- Industrial mass flow meters/ controllers
- Permanent no-weld tube fittings
- Precision industrial regulators & flow controllers
- Process control double block & bleeds
- Process control fittings, valves, regulators & manifold valves



Sealing & Shielding

Key Markets

- Aerospace
- Chemical processing
- Consumer
- Fluid power
- General industrial
- Information technology
- Life sciences
- Microelectronics
- Military
- Oil & gas
- Power generation
- Renewable energy
- Telecommunications
- Transportation

Key Products

- Dynamic seals
- Elastomeric o-rings
- Electro-medical instrument design & assembly
- EMI shielding
- Extruded & precision-cut, fabricated elastomeric seals
- High temperature metal seals
- Homogeneous & inserted elastomeric shapes
- Medical device fabrication & assembly
- Metal & plastic retained composite seals
- Shielded optical windows
- Silicone tubing & extrusions
- Thermal management
- Vibration dampening

ENGINEERING YOUR SUCCESS.

Parker Worldwide

Europe, Middle East, Africa

AE – United Arab Emirates,
Dubai

Tel: +971 4 8127100
parker.me@parker.com

AT – Austria, St. Florian
Tel: +43 (0)7224 66201
parker.austria@parker.com

AZ – Azerbaijan, Baku
Tel: +994 50 2233 458
parker.azerbaijan@parker.com

BE/NL/LU – Benelux,
Hendrik Ido Ambacht
Tel: +31 (0)541 585 000
parker.nl@parker.com

BG – Bulgaria, Sofia
Tel: +359 2 980 1344
parker.bulgaria@parker.com

BY – Belarus, Minsk
Tel: +48 (0)22 573 24 00
parker.poland@parker.com

CH – Switzerland, Etoy
Tel: +41 (0)21 821 87 00
parker.switzerland@parker.com

CZ – Czech Republic, Klecany
Tel: +420 284 083 111
parker.czechrepublic@parker.com

DE – Germany, Kaarst
Tel: +49 (0)2131 4016 0
parker.germany@parker.com

DK – Denmark, Ballerup
Tel: +45 43 56 04 00
parker.denmark@parker.com

ES – Spain, Madrid
Tel: +34 902 330 001
parker.spain@parker.com

FI – Finland, Vantaa
Tel: +358 (0)20 753 2500
parker.finland@parker.com

FR – France, Contamine s/Arve
Tel: +33 (0)4 50 25 80 25
parker.france@parker.com

GR – Greece, Piraeus
Tel: +30 210 933 6450
parker.greece@parker.com

HU – Hungary, Budaörs
Tel: +36 23 885 470
parker.hungary@parker.com

IE – Ireland, Dublin
Tel: +353 (0)1 466 6370
parker.ireland@parker.com

IL – Israel
Tel: +39 02 45 19 21
parker.israel@parker.com

IT – Italy, Corsico (MI)
Tel: +39 02 45 19 21
parker.italy@parker.com

KZ – Kazakhstan, Almaty
Tel: +7 7273 561 000
parker.easteurope@parker.com

NO – Norway, Asker
Tel: +47 66 75 34 00
parker.norway@parker.com

PL – Poland, Warsaw
Tel: +48 (0)22 573 24 00
parker.poland@parker.com

PT – Portugal
Tel: +351 22 999 7360
parker.portugal@parker.com

RO – Romania, Bucharest
Tel: +40 21 252 1382
parker.romania@parker.com

RU – Russia, Moscow
Tel: +7 495 645-2156
parker.russia@parker.com

SE – Sweden, Spånga
Tel: +46 (0)8 59 79 50 00
parker.sweden@parker.com

SK – Slovakia, Banská Bystrica
Tel: +421 484 162 252
parker.slovakia@parker.com

SL – Slovenia, Novo Mesto
Tel: +386 7 337 6650
parker.slovenia@parker.com

TR – Turkey, Istanbul
Tel: +90 216 4997081
parker.turkey@parker.com

UA – Ukraine, Kiev
Tel: +48 (0)22 573 24 00
parker.poland@parker.com

UK – United Kingdom, Warwick
Tel: +44 (0)1926 317 878
parker.uk@parker.com

ZA – South Africa, Kempton Park
Tel: +27 (0)11 961 0700
parker.southafrica@parker.com

North America

CA – Canada, Milton, Ontario
Tel: +1 905 693 3000

US – USA, Cleveland
Tel: +1 216 896 3000

Asia Pacific

AU – Australia, Castle Hill
Tel: +61 (0)2-9634 7777

CN – China, Shanghai
Tel: +86 21 2899 5000

HK – Hong Kong
Tel: +852 2428 8008

IN – India, Mumbai
Tel: +91 22 6513 7081-85

JP – Japan, Tokyo
Tel: +81 (0)3 6408 3901

KR – South Korea, Seoul
Tel: +82 2 559 0400

MY – Malaysia, Shah Alam
Tel: +60 3 7849 0800

NZ – New Zealand, Mt Wellington
Tel: +64 9 574 1744

SG – Singapore
Tel: +65 6887 6300

TH – Thailand, Bangkok
Tel: +662 186 7000

TW – Taiwan, Taipei
Tel: +886 2 2298 8987

South America

AR – Argentina, Buenos Aires
Tel: +54 3327 44 4129

BR – Brazil, Sao Jose dos Campos
Tel: +55 800 727 5374

CL – Chile, Santiago
Tel: +56 2 623 1216

MX – Mexico, Toluca
Tel: +52 72 2275 4200

EMEA Product Information Centre

Free phone: 00 800 27 27 5374

(from AT, BE, CH, CZ, DE, DK, EE, ES, FI, FR, IE, IL,
IS, IT, LU, MT, NL, NO, PL, PT, RU, SE, SK, UK, ZA)

US Product Information Centre

Toll-free number: 1-800-27 27 537

www.parker.com

